

GAS X5/MCE-LX4-EL

Burners for gas modulating (PID fully modulating) if equipped with addition of optional modulation kit and probe, low emissions certified in conformity with CE 676 class 4 ($\text{NO}_x \leq 60 \text{ mg/kWh}$).

They are composed by: die-cast aluminum body, fan at high pressurisation, combustion head with adjustment at high efficiency and high flame stability and protection cover with noise reduction plate.

Compact overall dimensions and disposition rationalized of the components with accessibility facilitated for operations of setting and maintenance.

Gas train complete of: one-block valve class A (1st stage slow opening + safety), minimum gas pressure switch, filter, stabiliser of gas pressure.

Complete of flange and gasket for installation on generator.

Electronic control box Lamtec BT3 with microprocessor and two servomotors for air and gas adjustment.

Interactive set-up LCD display.

The fuel / combustion air curve, with electronic cam device, is fully exploited, guaranteeing excellent performance in terms of accuracy and speed, even during the calibration phase. A microprocessor monitors the different stages of the process and allows the correct repetition of the sequences of operation.

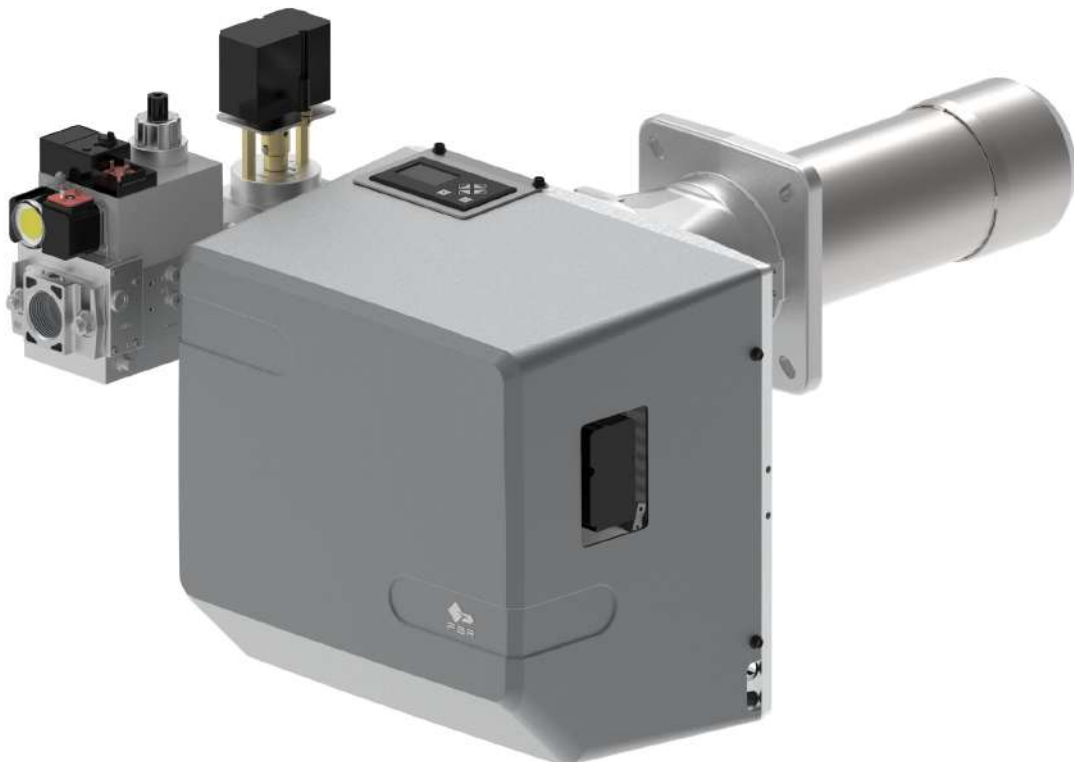

TECHNICAL DATA AND WORKING RANGE DIAGRAM GAS X5/MCE-LX4-EL (NATURAL GAS)

MODEL		GAS X5/MCE-LX4-EL
Thermal power min. 1°st. / min. 2°st. - max. 2° st.*	[Mcal/h]	58/155-344
Thermal power min. 1°st. / min. 2°st. - max. 2° st.*	[kW]	68/180-400
Gas flow G20 (NATURAL GAS) min. 1°st. / min. 2°st. - max. 2° st.*	[Nm³/h]	6.8/18.1-40.2
Fuel:		Natural gas (second family)
Fuel category:		I2R,I2H,I2L,I2E,I2E+,I2Er,I2ELL,I2E(R)
NOx **	[mg/kWh]	≤ 60 : class 4 (EN 676)
Intermittent working operation (min. 1 STOP every 24 hours) modulating		
Environmental conditions operation/storage:		-15...+40°C / -20...+70°C, rel. humidity max. 80%
Max temperature combustion air	[°C]	60
Minimum pressure gas train D1"-S NATURAL GAS ***	[mbar]	G20=55.2 - G25=88.2 - G25.3=77.7
Minimum pressure gas train D1"1/4-S NATURAL GAS ***	[mbar]	G20=31.5 - G25=46.9 - G25.3=44.3
Minimum pressure gas train D1"1/2-S NATURAL GAS ***	[mbar]	G20=15.9 - G25=23.7 - G25.3=22.4
Maximum pressure at the entry of the valves (Pe.max)	[mbar]	360
Nominal electric power	[W]	540
Fan motor	[W]	370
Nominal absorption	[A]	2.4
Power supply:		1/N~230V-50Hz
Degree of electric protection:		IP 40
Noisiness **** min-max	[dB(A)]	66-71
Weight burner *****	[kg]	35

* Conditions of reference: Environment temperature 20°C - barometric pressure 1013 mbars - Altitude 0 m o.s.l.

** To obtain this low Nox emission like in the declaration, it's necessary to couple the burner to the proper boiler for this application: boilers with 3 turns for the exhaust gas, condensing boilers and any generator with direct exhaust outlet and the thermal load isn't higher then 1,1 MW/m³.

*** Pressure of feeding of the gas to the ramp to get the maximum power of the burner considering against pressure in chamber of value combustion 0 (zero).

**** Measured sonorous pressure in the combustion laboratory , with functional burner on beta boiler to 1m of distance. (UNI EN ISO 3746). ***** For burner with cover in steel (F) to add 4 kg to the weight.

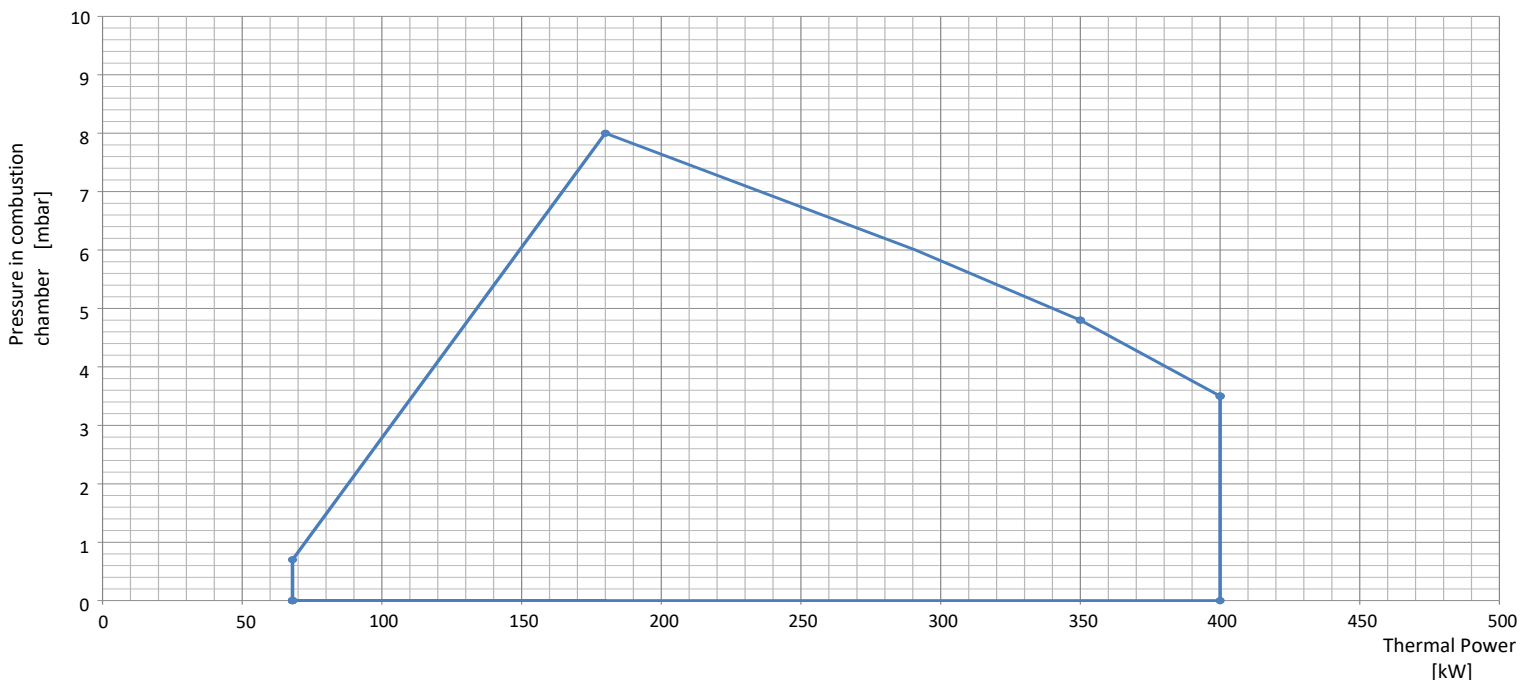

The firing rates has been obtained based on test boilers in accordance with EN676 standards and are indicative of matching the burner to the boiler. For the correct operation of the burner bruciatore, combustion chamber dimensions must be in accordance with current regulation. In case of non-compliance, contact the manufacturer.

TECHNICAL DATA AND WORKING RANGE DIAGRAM GAS X5/MCE-LX4-EL (L.P.G.)

MODEL		GAS X5/MCE-LX4-EL
Thermal power min. 1°st. / min. 2°st. - max. 2° st.*	[Mcal/h]	72/155-344
Thermal power min. 1°st. / min. 2°st. - max. 2° st.*	[kW]	84/180-400
Gas flow G31 (G.P.L.) min. 1°st. / min. 2°st. - max. 2° st.*	[Nm³/h]	3.2/7-15.6
Fuel:		G.P.L. (third family)
Fuel category:		I3B/P,I3+,I3P,I3B,I3R
NOx **	[mg/kWh]	≤ 60 : class 4 (EN 676)
Intermittent working operation (min. 1 STOP every 24 hours) modulating		
Environmental conditions operation/storage:		-15...+40°C / -20...+70°C, rel. humidity max. 80%
Max temperature combustion air	[°C]	60
Minimum pressure gas train D1"-S L.P.G. ***	[mbar]	G31=36.5
Minimum pressure gas train D1"1/4-S L.P.G. ***	[mbar]	G31=27.4
Minimum pressure gas train D1"1/2-S L.P.G. ***	[mbar]	G31=21.1
Maximum pressure at the entry of the valves (Pe.max)	[mbar]	360
Nominal electric power	[W]	540
Fan motor	[W]	370
Nominal absorption	[A]	2.4
Power supply:		1/N~230V-50Hz
Degree of electric protection:		IP 40
Noisiness **** min-max	[dB(A)]	66-71
Weight burner *****	[kg]	35

* Conditions of reference: Environment temperature 20°C - barometric pressure 1013 mbars - Altitude 0 m o.s.l.

** To obtain this low Nox emission like in the declaration, it's necessary to couple the burner to the proper boiler for this application: boilers with 3 turns for the exhaust gas, condensing boilers and any generator with direct exhaust outlet and the thermal load isn't higher then 1,1 MW/m³.

*** Pressure of feeding of the gas to the ramp to get the maximum power of the burner considering against pressure in chamber of value combustion 0 (zero).

**** Measured sonorous pressure in the combustion laboratory , with functional burner on beta boiler to 1m of distance. (UNI EN ISO 3746).

***** For burner with cover in steel (F) to add 4 kg to the weight.

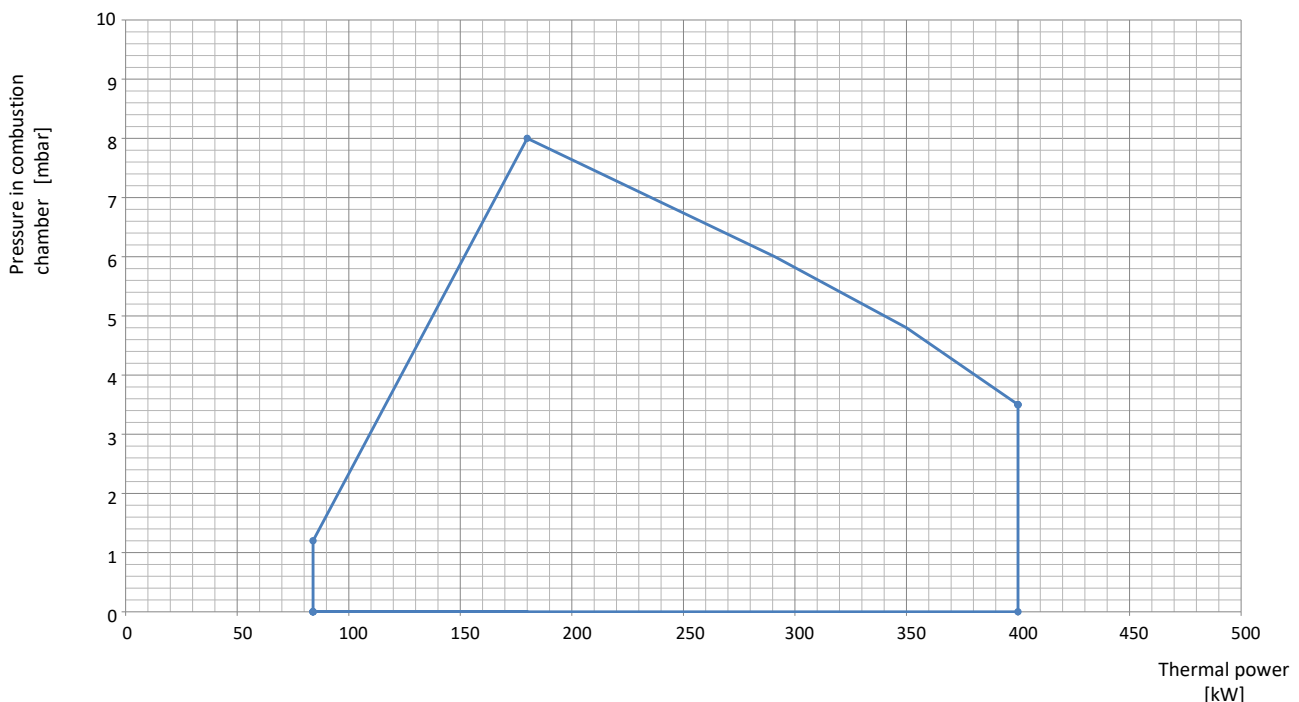

The firing rates has been obtained based on test boilers in accordance with EN676 standards and are indicative of matching the burner to the boiler. For the correct operation of the burner bruciatore, combustion chamber dimensions must be in accordance with current regulation. In case of non-compliance, contact the manufacturer.

DIMENSIONS [MM]

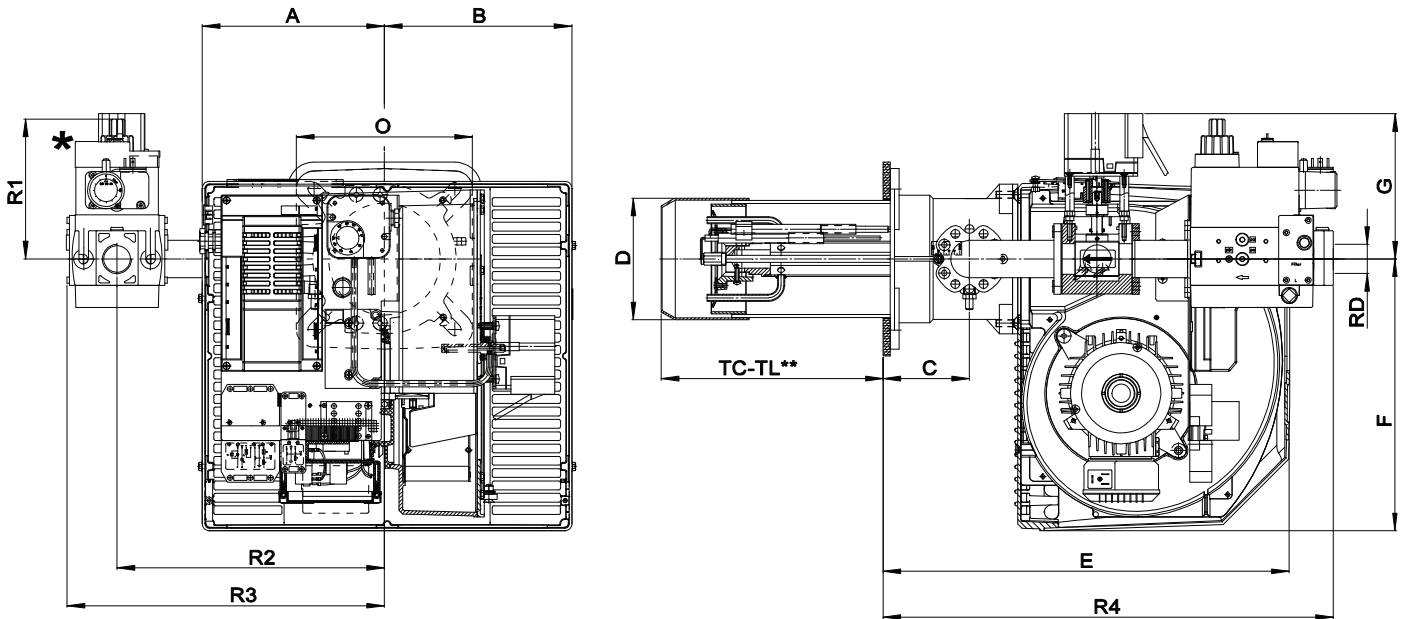
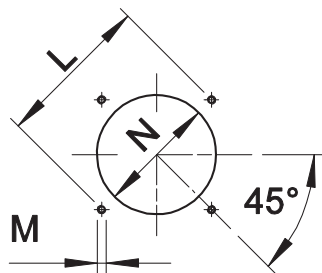

Fig. 2 Dimensions

MODEL	A	B	C	D	E	F	G	O	R1	R2	R3	R4	RD	Gas train weight
GAS X5/MCE-LX4-EL D1"-S	207	213	98	138	462	310	165	200	160	305	362	515	Rp 1"	6 kg
GAS X5/MCE-LX4-EL D1"1/4-S	207	213	98	138	462	310	165	200	160	305	362	515	Rp 1" 1/4	6 kg
GAS X5/MCE-LX4-EL D1"1/2-S	207	213	98	138	462	310	165	200	170	305	353	605	Rp 1" 1/2	8 kg

** SEE "FLAME TUBE LENGTH"

BOILER PLATE



The dimensions of the boiler plate must be as indicated in the drawing.

Fig. 3 Boiler plate

MODEL		L min	L max	M	N min	N max
GAS X5/MCE-LX4-EL	mm	205	226	M10	150	180

FLAME TUBE LENGTH

Flame tube length must be selected based on the specifications supplied by boiler manufacturer and, in any case, it must be greater than the thickness of the boiler door included its insulation. In case of boilers with flame inversion or front flue combustion chambers, it is necessary to insulate the area between the flame tube and front door with refractory material. This protection material must not impede flame tube extraction.

MODEL		TC *	TL *
GAS X5/MCE-LX4-EL	mm	250	335

* For different flame lengths, please contact our Technical-Sales Department.

PRODUCT SPECIFICATION

SHORT DESCRIPTION

Gas burners modulating (PID fully modulating) if equipped with modulation kit and probe, low emissions certified in conformity with CE 676 class 4 ($\text{NO}_x \leq 60 \text{ mg/kWh}$).

DETAILED SPECIFICATION

Gas burner modulating (PID fully modulating) with optional modulation kit and probe, low emissions certified in conformity with CE 676 class 4 ($\text{NO}_x \leq 60 \text{ mg/kWh}$), composed by:

- Die-cast aluminum body;
- Fan at high pressurisation;
- Combustion head with adjustment at high performance and elevated flame stability equipped with inox steel blast tube and steel flame disc;
- Combustible-air adjustment for optimal combustion value;
- Protection cover with noise reduction plate;
- Flange and insulating gasket for fixing at generator;
- Electronic control system for controlling and command the burner;
- Single-phase power supply;
- Safety air pressure switch to stop the burner in case of failed or anomalous fan operation;
- Spherical gas servocontrolled valve: progressive start and free way passage with total opening;
- Servomotor for air shutter;
- Servomotor for spherical gas valve;
- Mobile shutter with total closure when idle for minimize the energetic losses related at boiler cooling;
- Gas train complete of: one-block valve class A (1st stage slow opening + safety), minimum gas pressure switch, filter, stabiliser of gas pressure;
- Ionisation probe for flame detection;
- IP 40 electric protection level;
- Set up for the additional specific kit that transforms burner operation as modulating i.e.the modulating kit allows to supply any power between the minimum and maximum value based on instantaneous loading request.

CONFORMING TO:

- CE rules;
- 2014/30/UE Directive E.M.C.;
- 2014/35/UE Directive L.V.;
- 2006/42/CE - 2006/42/EG - 2006/42/EC Directive M.D.;
- GAS 2016/426/UE Regulation;
- Reference rules: EN676 (gas) – EN 746-2 (industrial thermoprocessing equipment).

STANDARD EQUIPMENT

- Isomart gasket;
- Flange with insulating gasket;
- Burner nameplate;
- Warranty;
- Instruction handbook for installation, use and maintenance.

OPTIONAL

- Power modulating kits for temperatures;
- Power modulating kits for pressures;
- Temperature probe $0^\circ\text{C} - 400^\circ\text{C}$ (PT 100 ohm at 0°C);
- Temperature probe $0^\circ\text{C} - 1200^\circ\text{C}$ (K probe);
- Pressure probe 0-3 bar, 0-6 bar, 0-16 bar, 0-20 bar, 0-30 bar;
- Antivibration couplings;
- Handle gas taps.