

K 3/2

Dual fuel gas/light-oil burners at 2 stages.

Composed by: aluminum body, an at high pressurisation and combustion head with adjustment at high efficiency and high flame stability.

Compact overall dimensions and disposition rationalized of the components with accessibility facilitated for the operations of setting and maintenance.

Available in the versions METHANE (natural gas) or G.P.L. (to specify at the order) on demand specific versions for town gas, coal gas or biogas.

Gas train complete of: one-block valve A class (1st stage + 2nd stage slow opening + safety), minimum gas pressure switch and stabiliser filter.

Complete of: flange and gasket for installation on generator, nozzles, flexible hoses and line filter.

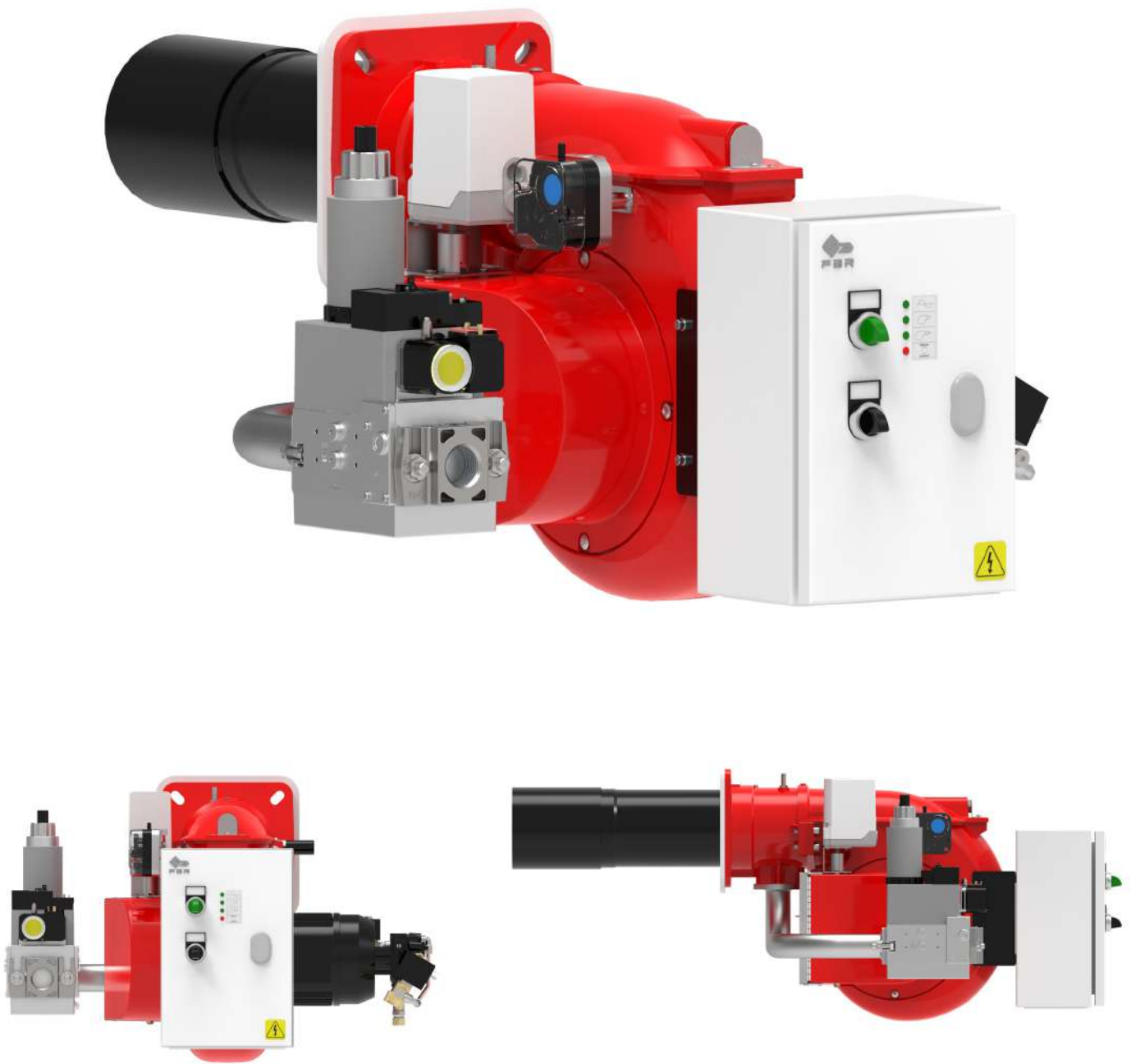

Fig. 1 K 3/2

TECHNICAL DATA AND OPERATING RANGE DIAGRAM K 3/2

MODEL		K 3/2
Thermal power min. 1°st. / min. 2°st. - max. 2°st. *	[Mcal/h]	55/100-200
Thermal power min. 1°st. / min. 2°st. - max. 2°st. *	[kW]	63.9/116-232
Gas flow G20 (NATURAL GAS) min. 1°st. / min. 2°st. - max. 2°st. *	[Nm³/h]	6.4/11.7-23.4
Gas flow G31 (L.P.G.) min. 1°st. / min. 2°st. - max. 2°st. *	[Nm³/h]	2.5/4.5-9
LIGHT-OIL flow min. 1°st. / min. 2°st. - max. 2°st. *	[kg/h]	5.5/10-20
Fuel: NATURAL GAS (second family) - L.P.G. (third family)		
Fuel category:	I2R,I2H,I2L,I2E,I2E+,I2Er,I2ELL,I2E(R)B/I3B/P,I3+,I3P,I3B,I3R	
Intermittent working operation (min. 1 stop every 24 hours) two stage		
Environmental conditions operation / storage:	-15...+40°C / -20...+70°C, rel. humidity max. 80%	
Max. temperature combustion air	[°C]	60
Minimum pressure gas train D1" - S NATURAL GAS/LPG **	[mbar]	19/29
Minimum pressure gas train D1"1/4 - S NATURAL GAS/LPG **	[mbar]	16.4/-
Minimum pressure gas train D1"1/2 - S NATURAL GAS/LPG **	[mbar]	14/-
Minimum pressure gas train D2"- S NATURAL GAS/LPG **	[mbar]	13/-
Maximum pressure at the entry of valves (Pe. max)	[mbar]	360
Nominal electric power	[W]	400
Fan motor	[W]	370
Nominal absorption powers	[A]	2.1
Nominal absorption auxiliary	[A]	0.7
Power supply:	1/N~230V-50Hz	
Electric protection degree:	IP 40	
Noisiness *** min. - max.	[dB(A)]	68-70
Burner weight	[kg]	38

* Reference conditions: Environment temperature 20°C - Barometric pressure 1013 mbars - Altitude 0 metre (sea level).

** Minimal feeding-gas pressure to the gas train to get the maximum power of the burner, considering counter-pressure in combustion chamber of value 0 (zero).

*** Measured sonorous pressure in the laboratory combustion, with functional burner on beta boiler to 1 metre of distance (UNI EN ISO 3746 law).

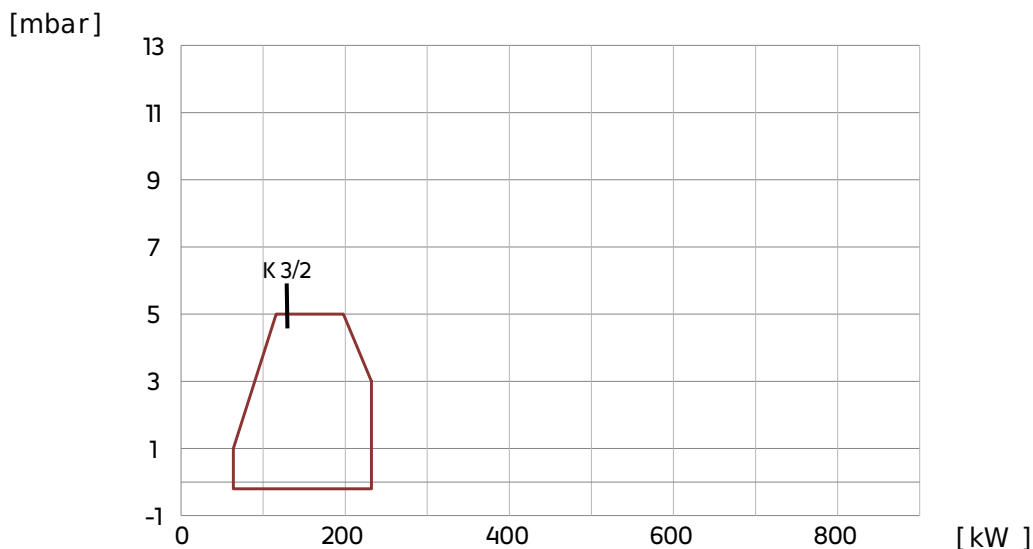

Fig. 2 X = Thermal power Y = Pressure in combustion chamber

The firing rates has been obtained based on test boilers in accordance with EN676 standards and are indicative of matching the burner to the boiler. For the correct operation of the burner bruciatore, combustion chamber dimensions must be in accordance with current regulation. In case of non-compliance, contact the manufacturer.



FBR

DIMENSIONS [MM]

DUAL FUEL GAS/LIGHT-OIL BURNERS AT TWO STAGES

SK073505_C_en

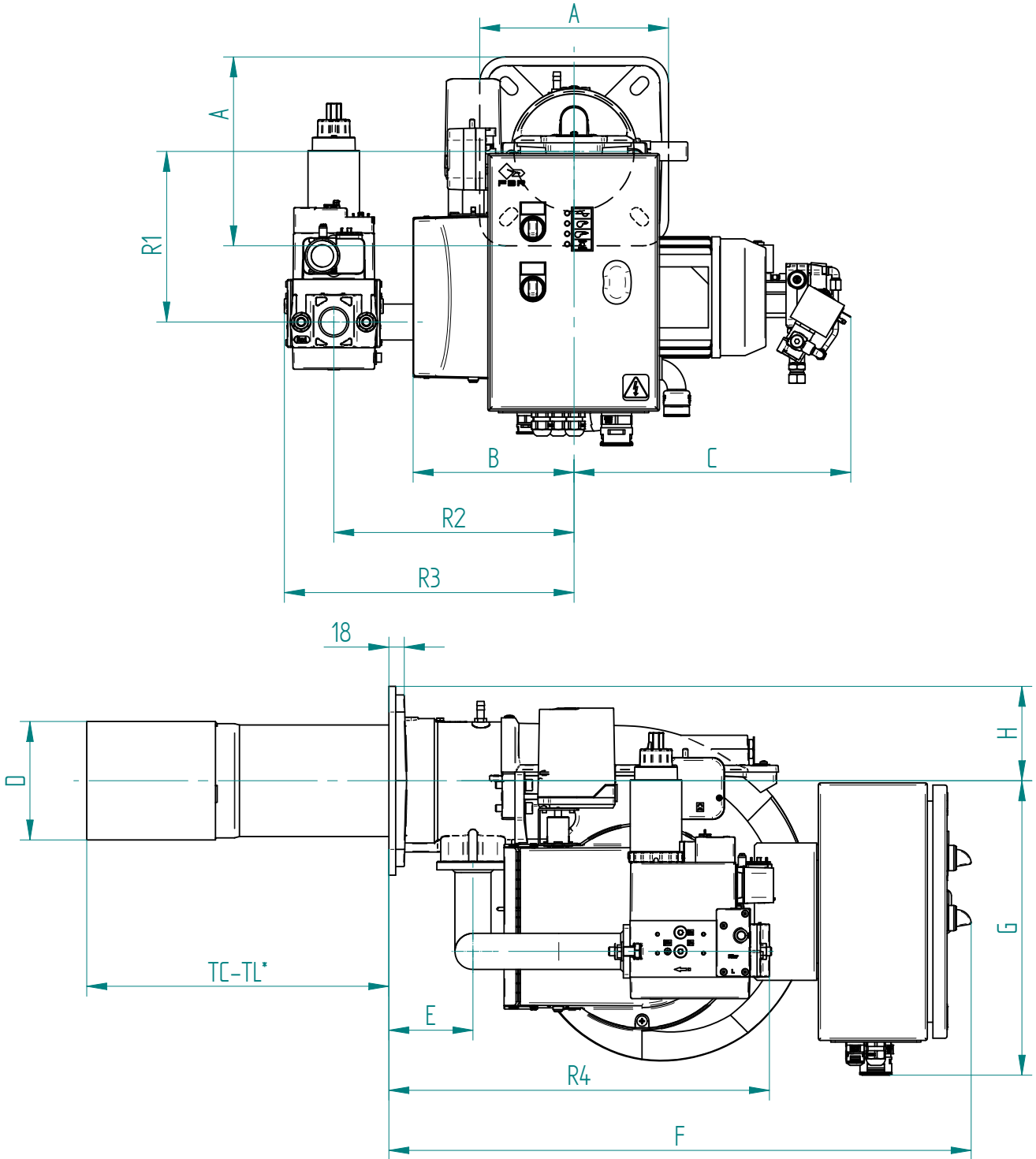

Fig. 3 Dimensions: K 3/2

MODEL	A	B	C	D	E	F	G	H	R1	R2	R3	R4	RD	Gas train weight
K 3/2 D1" - S	220	188	323	138	98	679	343	110	204	280	338	444	Rp 1	6 kg
K 3/2 D1"1/4 - S	220	188	323	138	98	679	343	110	204	280	338	444	Rp 1 1/4	6 kg
K 3/2 D1"1/2 - S	220	188	323	138	98	679	343	110	204	280	346	592	Rp 1 1/2	9 kg
K 3/2 D2" - S	220	188	323	138	98	679	343	122	204	280	346	592	Rp 2	10.6 kg

* TC-TL: see "flame tube length"



FBR

BOILER PLATE

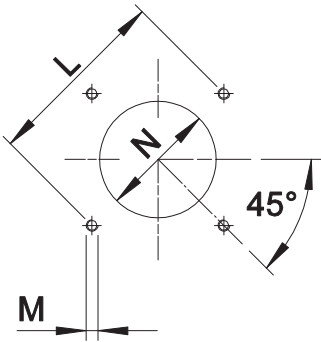

Fig. 4 Boiler plate

MODEL		L min	L max	M	N
K 3/2	mm	205	226	M10	150

FLAME TUBE LENGTH

Flame tube length must be selected based on the specifications supplied by boiler manufacturer and, in any case, it must be greater than the thickness of the boiler door included its insulation.
 In case of boilers with flame inversion or front flue combustion chambers, it is necessary to insulate the area between the flame tube and front door with refractory material. This protection material must not impede flame tube extraction.

MODEL		TC	TL*
K 3/2	mm	250	350

* For different flame lengths, please contact our Technical-Sales Department.

PRODUCT SPECIFICATION**SHORT DESCRIPTION**

Dual fuel gas/light-oil burners at two stages.

DETAILED SPECIFICATION

Dual fuel gas/light-oil burners at two stages, composed by:

- Aluminium frame;
- Fan at high pressurisation;
- Combustion head with adjustment at high performance and elevated flame stability equipped with blast tube and flame disc;
- Flange and insulating gasket for fixing at boiler;
- Single-phase power supply;
- Manual switch for the fuel selection gas/light-oil;
- Safety air pressure switch to stop the burner in lock-out in case of failed or anomalous fan operation;
- Equipped with gas train with one-block valve A class (1st stage + 2nd stage slow opening + safety), minimum gas pressure switch and stabiliser filter;
- Optional gas valve proving system VPS;
- Light-oil pump turns on simultaneously with the fan motor;
- Optional maximum gas pressure switch;
- UV probe for flame detection;
- Servomotor for air shutter and for the consent of the 2nd stage operation;
- Moving shutter with total closure when idle in order to reduce at the least energy losses related to boiler cooling down;
- IP 40 electric protection level.

CONFORMING TO:

- CE rules;
- 2014/30/UE Directive E.M.C.;
- 2014/35/UE Directive L.V.;
- 2014/68/EU Directive M.D.;
- 97/23/CE Directive P.E.D.;
- 2009/142/CE Directive GAS;
- Reference rules: EN676 (gas) - EN267 (liquid fuel) - EN746-2 (industrial thermoprocessing equipment).

STANDARD EQUIPMENT

- Flexible pipes;
- Line filter;
- Isomart gasket;
- Nozzle;
- Flange with insulating gasket;
- Burner nameplate;
- Warranty;
- Instruction handbook for installation, use and maintenance.

OPTIONAL

- Noise protection;
- Antivibration couplings;
- Handle gas taps.