

GAS P130/MCE EVO - GAS P160/MCE

Burners for gas two stages progressive (hi-low flame) or modulating (PID fully modulating) if equipped with addition of optional modulation kit and probe.

Composed by: die-cast aluminum body, high pressurisation air blower and combustion head with adjustment at high efficiency and high flame stability.

Compact overall dimensions and disposition rationalized of the components with accessibility facilitated for easy setting and maintenance.

Available in the versions METHANE (natural gas) or L.P.G. (to specify at the order) on demand specific versions for town gas, coal gas or biogas.

Gas train completely assembled and tested; composed by working valve with flow adjustment, safety valve, minimum gas pressure switch, valve proving system and gas filter + gas pressure stabiliser.

Complete of flange and gasket for installation on generator.



TECHNICAL DATA GAS P130/MCE EVO - GAS P160/MCE

MODEL		GAS P130/MCE EVO	GAS P160/MCE
Thermal power min. 1°st. / min. 2°st. - max. 2°st. *	[Mcal/h]	206/612-1324	275/765-1647
Thermal power min. 1°st. / min. 2°st. - max. 2°st. *	[kW]	240/712-1540	320/890-1915
Gas flow G20 (NATURAL GAS) min. 1°st. / min. 2°st. - max. 2°st. *	[Nm³/h]	24/71.5-155	32.2/89.5-192
Gas flow G31 (L.P.G.) min. 1°st. / min. 2°st. - max. 2°st. *	[Nm³/h]	9.3/27.6-59.8	12.4/34.5-74.2
Fuel: NATURAL GAS (second family) - L.P.G. (third family)			
Fuel category:	I2R,I2H,I2L,I2E,I2E+,I2Er,I2ELL, I2E(R) I3B/P,I3+,I3P,I3B,I3R		
Intermitted working operation (min. 1 stop every 24 hours) two stages progressive or modulating			
Environmental conditions operation / storage:	-15...+40°C / -20...+70°C, rel. humidity max. 80%		
Max. temperature combustion air	[°C]	60	60
Min. pressure gas train D2"-S NATURAL GAS/L.P.G. **	[mbar]	52.4/28.2	64.5/40.4
Min. pressure gas train DN65-FS65 NATURAL GAS/L.P.G. **	[mbar]	29.9/21	35.8/29.2
Min. pressure gas train DN80-FS80 NATURAL GAS/L.P.G. **	[mbar]	27.4/18.4	25.8/25.3
Max. pressure at the entry of valves (Pe. max) (D2")	[mbar]	360	360
Max. pressure at the entry of valves (Pe. max) (DN65 - DN80)	[mbar]	500	500
Nominal electric power	[kW]	2.4	4.2
Fan motor	[kW]	2.2	4
Nominal motor current absorption	[A]	4.35	7.45
Nominal auxiliary absorption	[A]	0.7	0.6
Power supply:	3~400V,1N~230V - 50Hz		
Electric protection degree:		IP 40	IP 40
Noisiness *** min. - max.	[dB(A)]	82-83	84.3-86.6

* Reference conditions: Environment temperature 20°C - Barometric pressure 1013 mbars - Altitude 0 metre (sea level).

** Minimal feeding-gas pressure to the gas train to get the maximum power of the burner, considering counter-pressure in combustion chamber of value 0 (zero).

*** Measured sonorous pressure in the laboratory combustion, with functional burner on beta boiler to 1 metre of distance (UNI EN ISO 3746 law - method of control Class 3 - The tolerance of the measured pressure can be taken equal to ± 1 [dB(A)]).

OPERATING RANGE DIAGRAMS

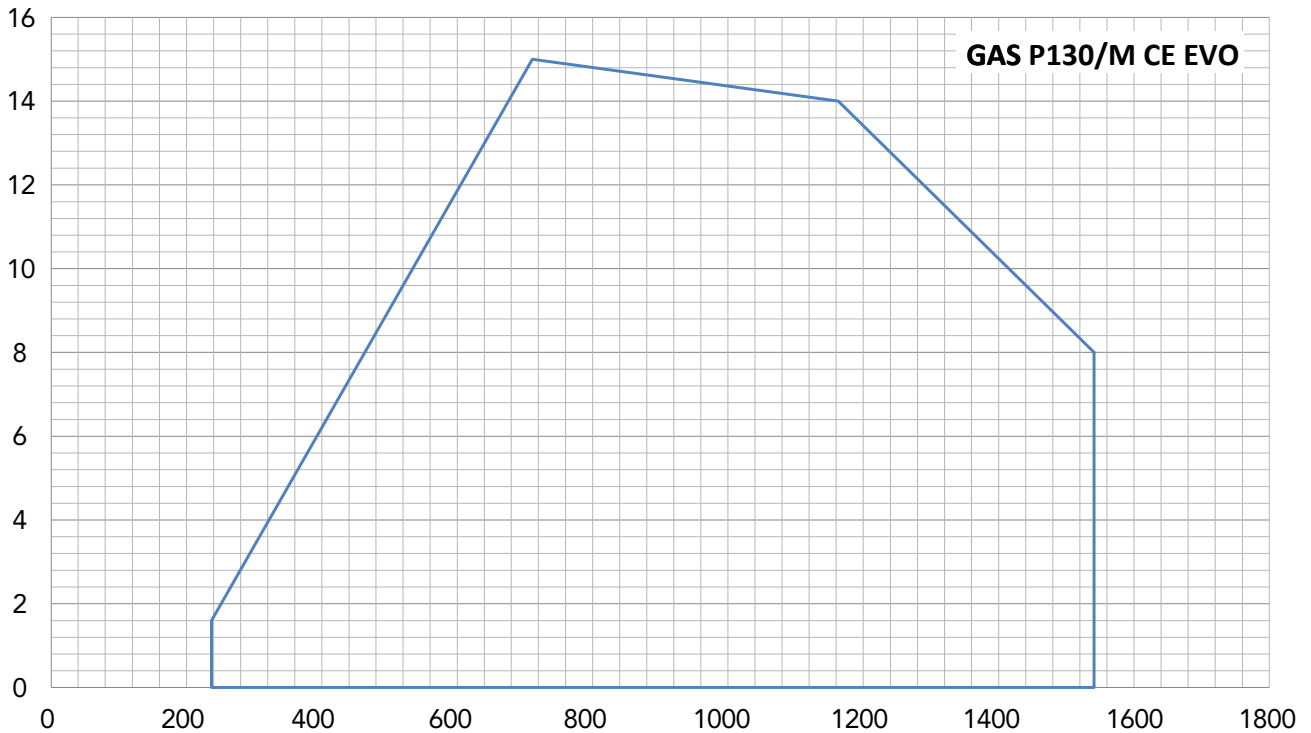

Fig. X = Thermal power [kW] Y = Pression in the combustion chamber [mbar]

The firing rates has been obtained based on test boilers in accordance with EN676 standards and are indicative of matching the burner to the boiler. For the correct operation of the burner, combustion chamber dimensions must be in accordance with current regulation. In case of non-compliance, contact the manufacturer.

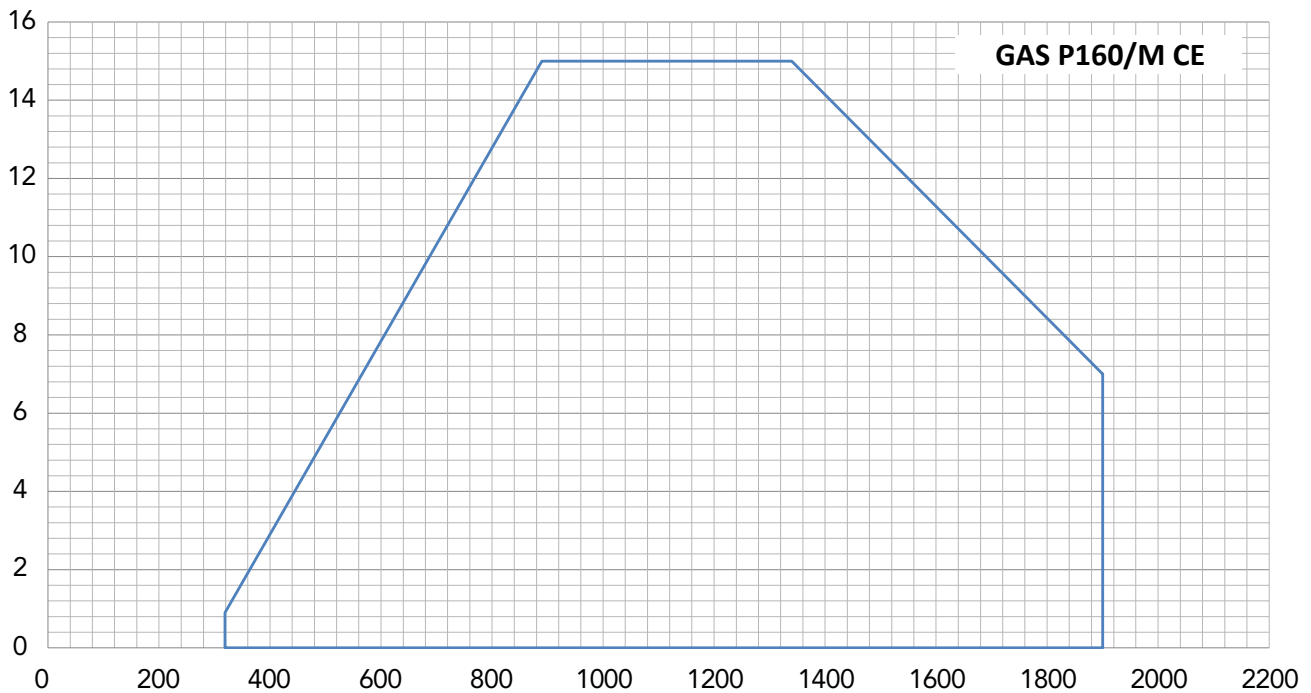

Fig. X = Thermal power [kW] Y = Pression in the combustion chamber [mbar]

The firing rates has been obtained based on test boilers in accordance with EN676 standards and are indicative of matching the burner to the boiler. For the correct operation of the burner, combustion chamber dimensions must be in accordance with current regulation. In case of non-compliance, contact the manufacturer.

DIMENSIONS GAS P130/MCE EVO [mm]

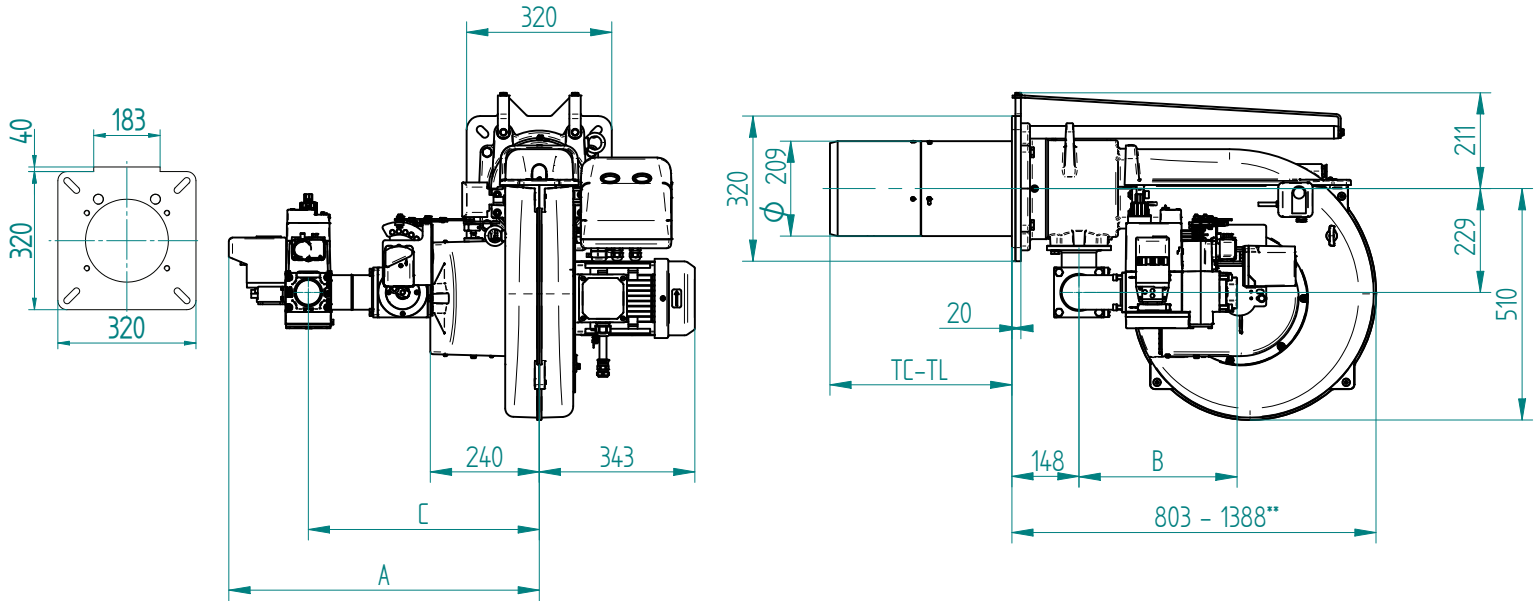

Fig. Dimensions GAS P130/MCE EVO

GAS TRAIN	A	B	C
D2"-S	684	350	510
DN65-FS65	686	393	510
DN80-FS80	740	433	550

** Overall dimension with the burner out in position of maintenance.

TC - TL: see "flame tube length"

DIMENSIONS GAS P160/MCE [mm]

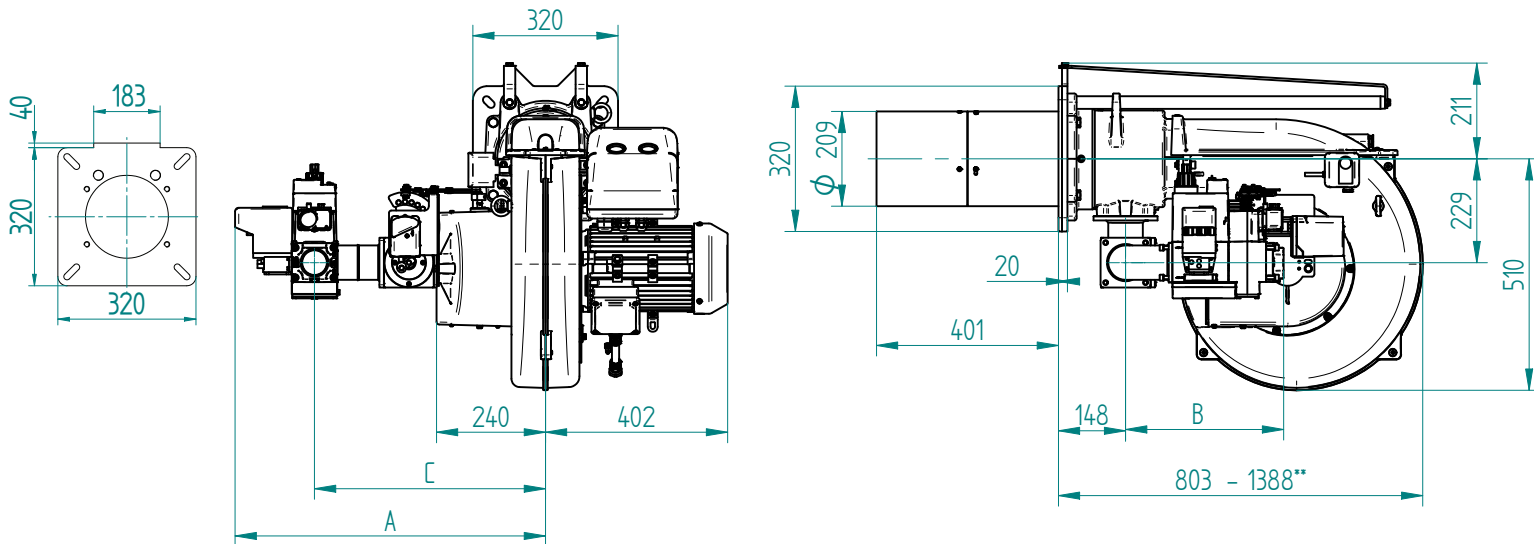
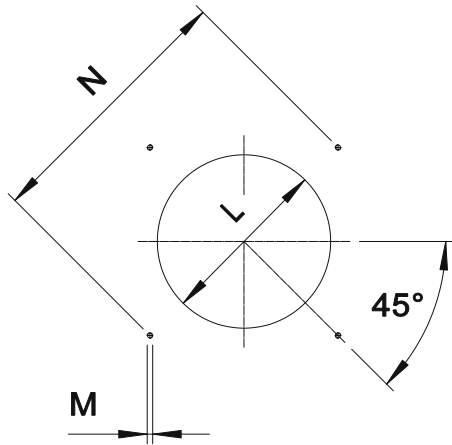

Fig. Dimensions GAS P160/MCE

GAS TRAIN	A	B	C
D2"-S	684	350	510
DN65-FS65	686	393	510
DN80-FS80	740	433	550

** Overall dimension with the burner out in position of maintenance.

TC - TL: see "flame tube length"



*** Suggested dimension of connection between burner and generator.

Fig. Boiler plate

MODEL		L min	L ***	L max	M	N min	N max
GAS P130/MCE EVO	mm	220	220	250	M14	340	368
GAS P160/MCE	mm	220	220	250	M14	340	368

FLAME TUBE LENGTH

Flame tube length must be selected based on the specifications supplied by boiler manufacturer and, in any case, it must be greater than the thickness of the boiler door included its insulation.
In case of boilers with flame inversion or front flue combustion chambers, it is necessary to insulate the area between the flame tube and front door with refractory material. This protection material must not impede flame tube extraction.

MODEL		TC	TL ****
GAS P130/MCE EVO	mm	280	400
GAS P160/MCE	mm	280	400

**** For different flame lengths, please contact our Technical-Sales Department.

BURNER SIGNAL DESCRIPTION

In the picture below there are indicated all the signalation present on the burner:

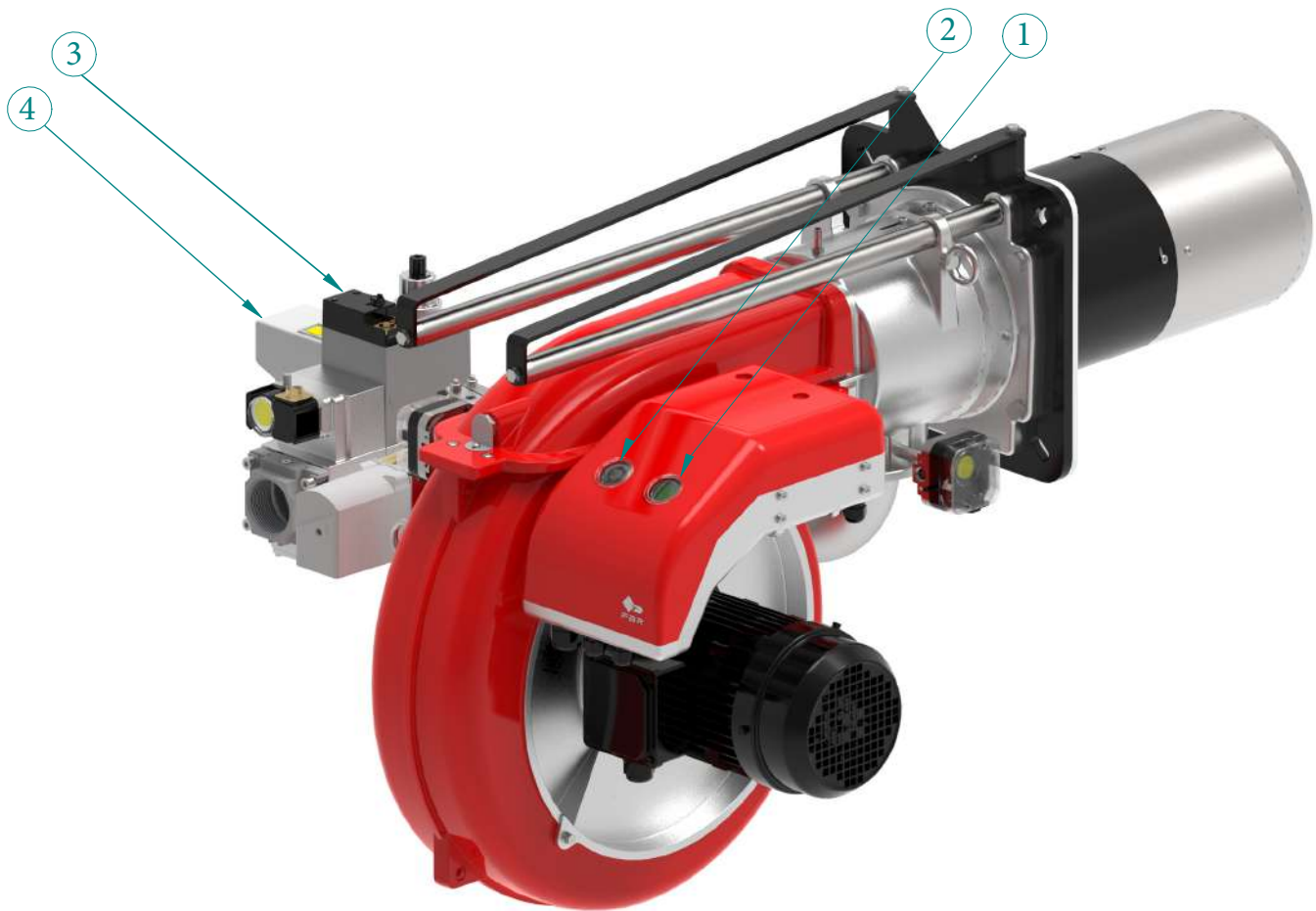



Fig. Burner signal description

LEGEND

- 1) ON/OFF button
- 2) Reset from lockout button + status lamp
- 3) GAS valve lamp *
- 4) VPS status lamps

* In the gas train DN65-FS65 and DN80-FS80 there are 2 lamps.

 The multicolor signal lamp in the lockout reset button (pos.2) is the key indicating element for visual diagnostics and interface diagnostics.

In normal operation, the different operating states are indicated in the form of color codes; please refer to electrical device handbook supplied with the present instructions.

 After a non-alterable lockout, the red signal lamp in the lockout reset button (pos.2) lights up. By pressing the lockout reset button (pos.2) for more than 3 seconds, the visual diagnostics of the cause of fault can be activated; please refer to electrical device handbook supplied with the present instructions.

For close the diagnostics mode and for switch on the burner again, it is necessary to reset the burner control. Press the lockout reset button (pos.2) for about 1 second (<3 seconds).

 After a non-alterable lockout, the red signal lamp in the lockout reset button (pos.2) lights up. For reset the control box press the lockout reset button (pos.2) for about 1 second (<3 seconds).



GAS BURNERS TWO STAGES PROGRESSIVE OR MODULATING

SK073067_A_en
mod: GAS P130/MCE EVO
GAS P160/MCE

PRODUCT SPECIFICATION

SHORT DESCRIPTION

Burners for gas two stages progressive (hi-low flame) or modulating (PID fully modulating) if equipped with addition of optional modulation kit and probe.

DETAILED SPECIFICATION

Burner for gas two stages progressive (hi-low flame) or modulating (PID fully modulating) if equipped with addition of optional modulation kit and probe; composed by:

- Die-cast aluminum body;
- High pressurisation air blower, with reverse blades for model GAS P130/M CE EVO;
- Combustion head with adjustment at high performance and elevated flame stability equipped with inox steel blast tube and inox steel flame disc;
- Flange and insulating gasket for fixing at boiler;
- Three-phase power supply;
- Safety air pressure switch to stop the burner in lock-out in case of failed or anomalous fan operation;
- Gas train with safety valve class A, adjustment valve class A and valve proving system;
- Ionisation probe for flame detection;
- IP 40 electric protection level;
- Spherical gas valve servo-controlled; progressive start and free way passage with total opening;
- Servomotor for air shutter and for the spherical gas valve;
- Moving shutter with total closure when idle in order to reduce at the least energy losses related to boiler cooling down;
- Supports and tierods for burner extraction;
- Easy extraction of combustion head without get off the burners by bolier;
- Maximum gas pressure switch to stop the burner in lock-out in case of the gas pressure is higher then the set point value;
- Set up for the additional specific kit that transforms burner operation as modulating i.e. the modulating kit allows to supply any power between the minimun and the maximum value based on instantaneous loading request.

CONFORMING TO:

- CE rules;
- 2014/30/UE Directive E.M.C.;
- 2014/35/UE Directive L.V.;
- 2006/42/CE - 2006/42/EG - 2006/42/EC Directive M.D.;
- 2016/426/UE Regulation;
- Reference rules: EN676 (gas) – EN 746-2 (industrial thermoprocessing equipment).

STANDARD EQUIPMENT

- Isomart gasket;
- Flange with insulating gasket;
- Burner nameplate;
- Warranty;
- Instruction handbook for installation, use and maintenance.

OPTIONAL

- Power modulating kits for temperatures;
- Power modulating kits for pressures;
- Temperature probe 0°C-400°C (PT 100 a 0° C);
- Temperature probe 0°C-1200°C (K probe);
- Pressure probe 0-3 bar, 0-6 bar. 0-16 bar, 0-20 bar, 0-30 bar;
- Noise protection;
- Antivibration couplings;
- Handle gas taps.