

FGP 50/2 EVO-3

Burners for light-oil two stages.

They are composed by: fan at high pressurisation and reverse blades, combustion head with adjustment at high efficiency and high flame stability and hydraulic system of regulation combustive air on the two stages of flame. Compact overall dimensions and disposition rationalized of the components with accessibility facilitated for the operations of setting and maintenance.

Complete of nozzles, flexible hoses and line filter.

Complete of flange and gasket for installation on generator.

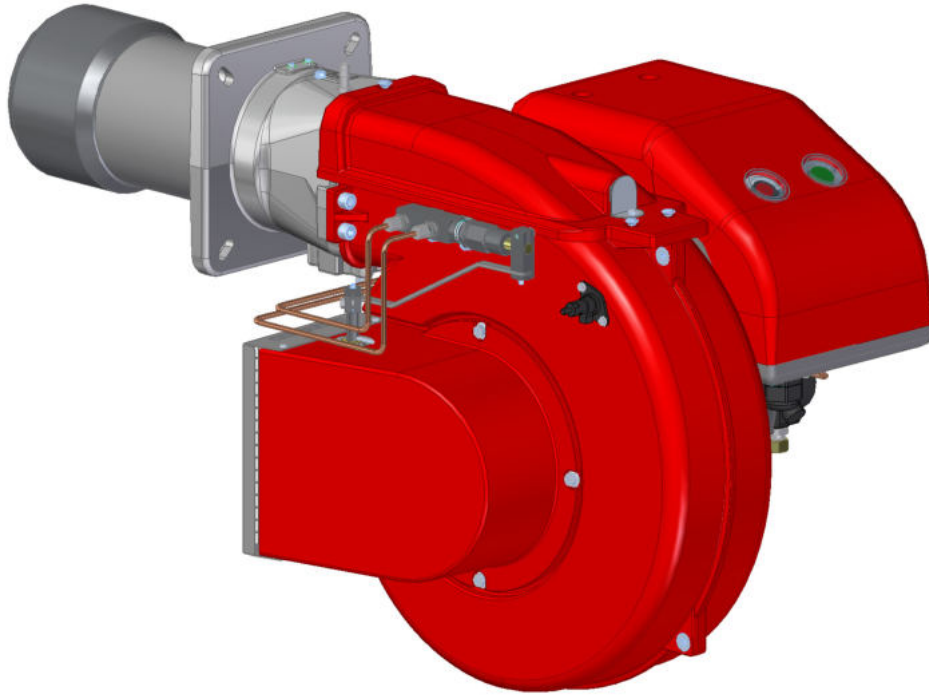

Fig. 1 FGP 50/2 EVO-3

TECHNICAL DATA FGP 50/2 EVO-3

MODEL	FGP 50/2 EVO-3	
Flow min. 1°st. / min. 2°st. - max. 2°st. *	[kg/h]	9.9/20-53.1
Thermal power min. 1°st. / min. 2°st. - max. 2°st. *	[Mcal/h]	100.1/204-541.8
Thermal power min. 1°st. / min. 2°st. - max. 2°st. *	[kW]	117.4/237-630
Fuel: LIGHT-OIL 1.5°E at 20°C = 6.2 cSt = 35 sec Redwood N°1		
Intermittent working operation (min. 1 stop every 24 hours) two stages		
Environmental conditions operation / storage:	-15...+40°C / -20...+70°C, rel. humidity max. 80%	
Max. temperature combustion air	[°C]	60
Nominal electric power	[kW]	1.1
Fan motor	[kW]	0.74
Nominal motor current absorption	[A]	1.8
Nominal auxiliary absorption	[A]	0.3
Power supply:	3~400V, 1N~230V - 50Hz	
Electric protection degree:	IP 40	
Noisiness ** min-max	[dBA]	71-73
Burner weight ***	[kg]	31

* Reference conditions: Environment temperature 20°C - Barometric pressure 1013 mbars - 0 (zero) Height meters above mean sea level.

** Sound power level detected at a distance of 1 meter in the combustion lab with burner working on boiler (UNI EN ISO 3746).

*** For burner FGP 50/2 EVO-3 long head add 1 kg to the weight.

OPERATING RANGE DIAGRAM FGP 50/2 EVO-3

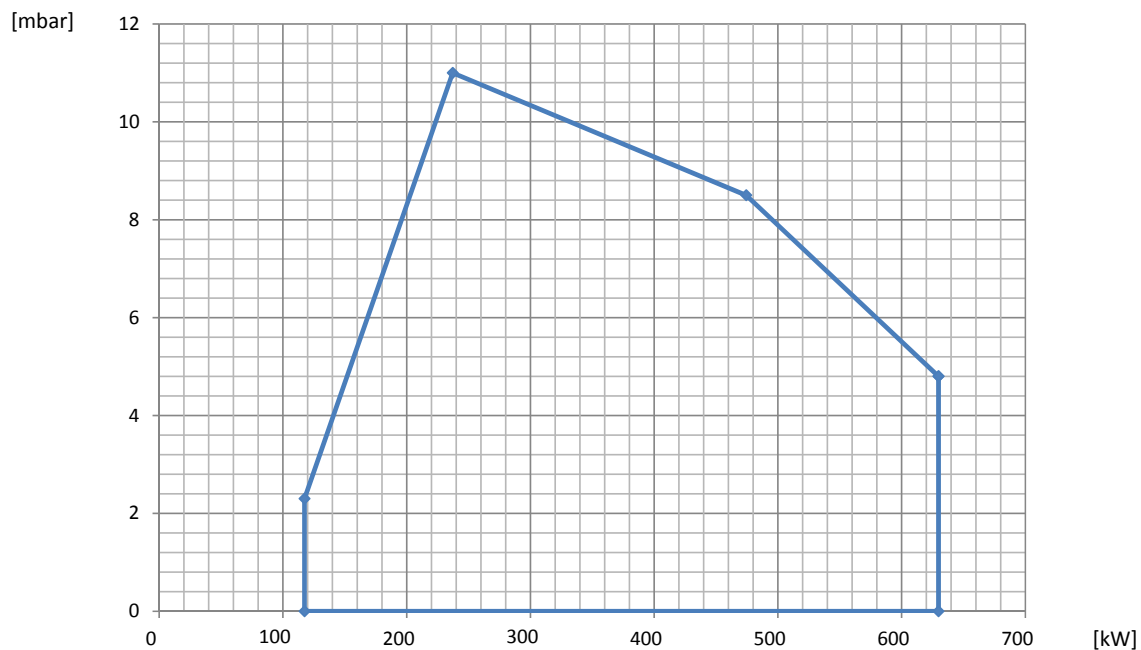

Fig. 2 X = Thermal power Y = Pression in the combustion chamber

The firing rates has been obtained based on test boilers in accordance with EN267 standards and are indicative of matching the burner to the boiler. For the correct operation of the burner, combustion chamber dimensions must be in accordance with current regulation. In case of non-compliance, contact the manufacturer.

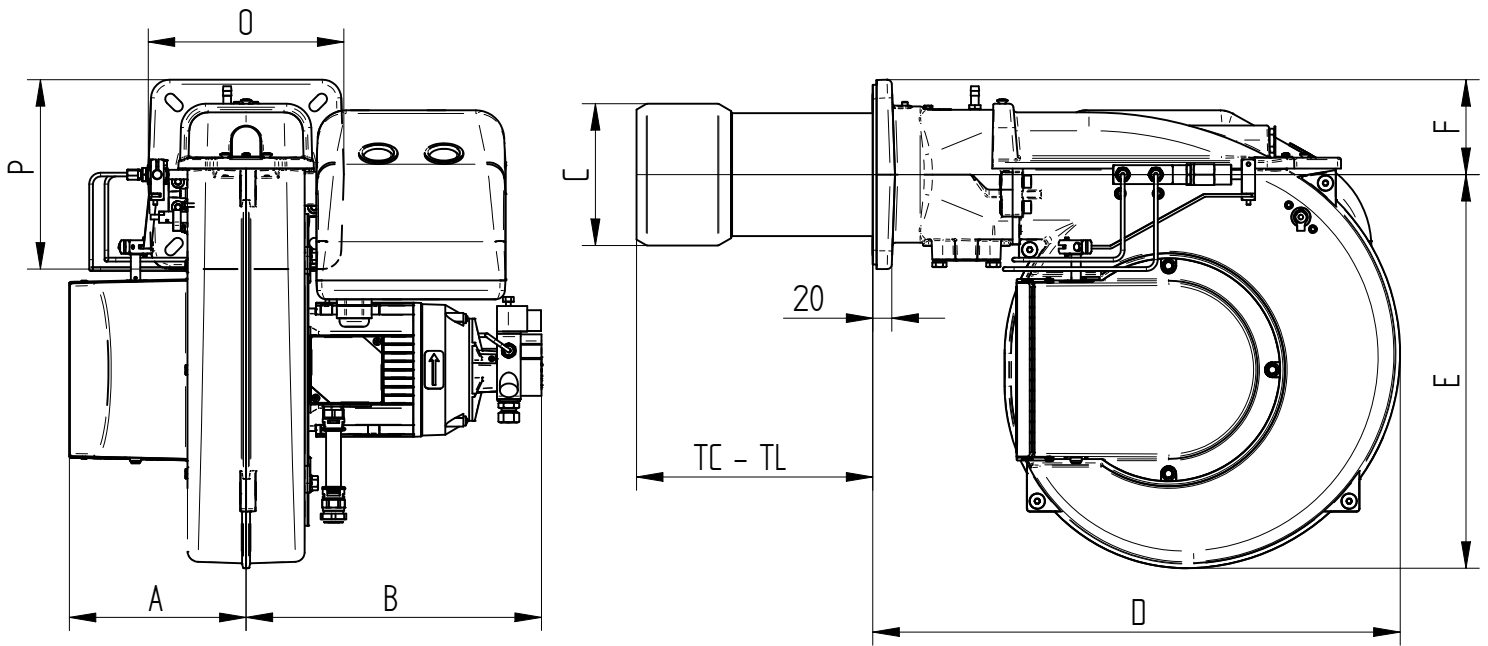
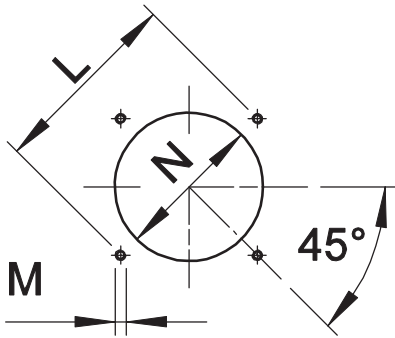

Fig. 3 Dimensions FGP 50/2 EVO-3

MODEL	A	B	C	D	E	F	O	P
FGP 50/2 EVO-3	187	314	150	558	417	100	207	200

* see "flame tube length"



* Suggested dimension of connection between burner and generator.

Fig. 4 Boiler plate

MODEL		L min	L max	M	N min	N *	N max
FGP 50/2 EVO-3	mm	205	226	M10	160	160	180

FLAME TUBE LENGTH

Flame tube length must be selected based on the specifications supplied by boiler manufacturer and, in any case, it must be greater than the thickness of the boiler door included its insulation.

In case of boilers with flame inversion or front flue combustion chambers, it is necessary to insulate the area between the flame tube and front door with refractory material. This protection material must not impede flame tube extraction.

MODEL		TC	TL **
FGP 50/2 EVO-3	mm	250	335

** For different flame lengths, please contact our Technical-Sales Department.

BURNER SIGNAL DESCRIPTION

In the picture below there are indicated all the signalation present on the burner:

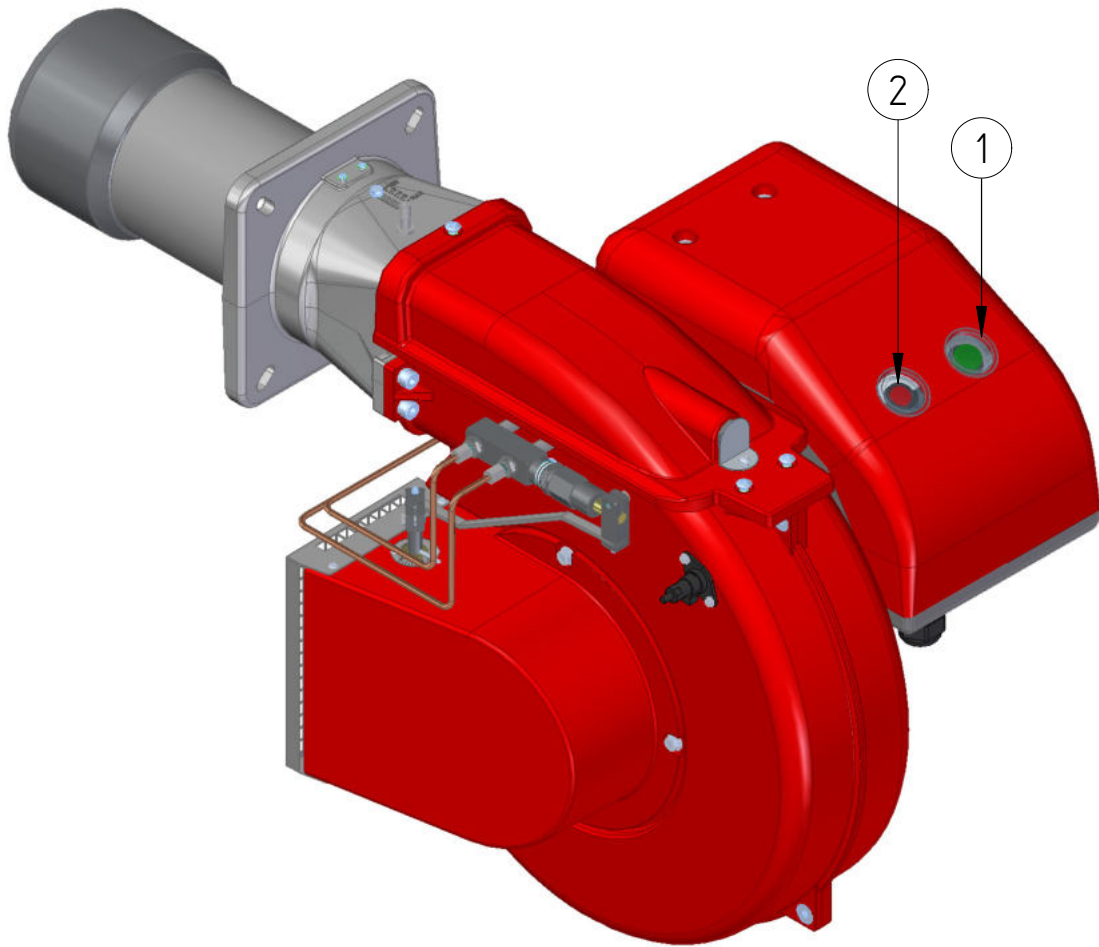

Fig. 5 Burner signal description

LEGEND

- 1) ON/OFF button
- 2) Reset from lockout button + status lamp

💡 The multicolor signal lamp in the lockout reset button (pos.2) is the key indicating element for visual diagnostics and interface diagnostics.
In normal operation, the different operating states are indicated in the form of color codes; please refer to electrical device handbook supplied with the present instructions.

💡 After a non-alterable lockout, the red signal lamp in the lockout reset button (pos.2) lights up.
By pressing the lockout reset button (pos.2) for more than 3 seconds, the visual diagnostics of the cause of fault can be activated; please refer to electrical device handbook supplied with the present instructions.

For close the diagnostics mode and for switch on the burner again, it is necessary to reset the burner control.
Press the lockout reset button (pos.2) for about 1 second (<3 seconds).

💡 After a non-alterable lockout, the red signal lamp in the lockout reset button (pos.2) lights up.
For reset the control box press the lockout reset button (pos.2) for about 1 second (<3 seconds).

PRODUCT SPECIFICATION

SHORT DESCRIPTION

Light-oil burners two stages.

DETAILED SPECIFICATION

Light-oil burner two stages composed by:

- Fan at high pressurisation and reverse blades;
- Combustion head with adjustment at high performance and elevated flame stability;
- Flange and insulating gasket for fixing at boiler;
- Three-phase power supply;
- Photoresistance for flame detection;
- IP 40 electric protection level;
- Easy extraction of combustion head without get off the burners by boiler.

CONFORMING TO:

- CE rules;
- 2014/30/UE Directive E.M.C.;
- 2014/35/UE Directive L.V.;
- 2006/42/CE Directive M.D.;
- 2014/68/UE (ART.4,PAR.3) Directive P.E.D.;
- Reference rules: EN267 (liquid fuel) - EN746-2 (industrial thermoprocessing equipment).

STANDARD EQUIPMENT

- Flexible hoses for connection;
- Line filter;
- Isomart gasket;
- Nozzles;
- Flange with insulating gasket;
- Burner nameplate;
- Warranty;
- Instruction handbook for installation, use and maintenance.

OPTIONAL

- Noise protection.