

GAS XP80/2 CE

Gas burners two stages with: aluminum body, fan at high pressurisation and combustion head with adjustment at high efficiency and high flame stability.

Compact overall dimensions and disposition rationalized of the components with accessibility facilitated for the operations of setting and maintenance.

The burner is mounted on supports and tierods for burner extraction this permits retreat to disassemble and check the flame tube and the combustion head.

Available in the versions METHANE (natural gas) or L.P.G. (to specify at the order) on demand specific versions for town gas, coal gas or biogas.

Gas train completely assembled and tested; complete of two stages working valve with flow adjustment, safety valve, minimum gas pressure switch and stabiliser filter of gas pressure.

Complete off lunge and gasket for installation on generator.

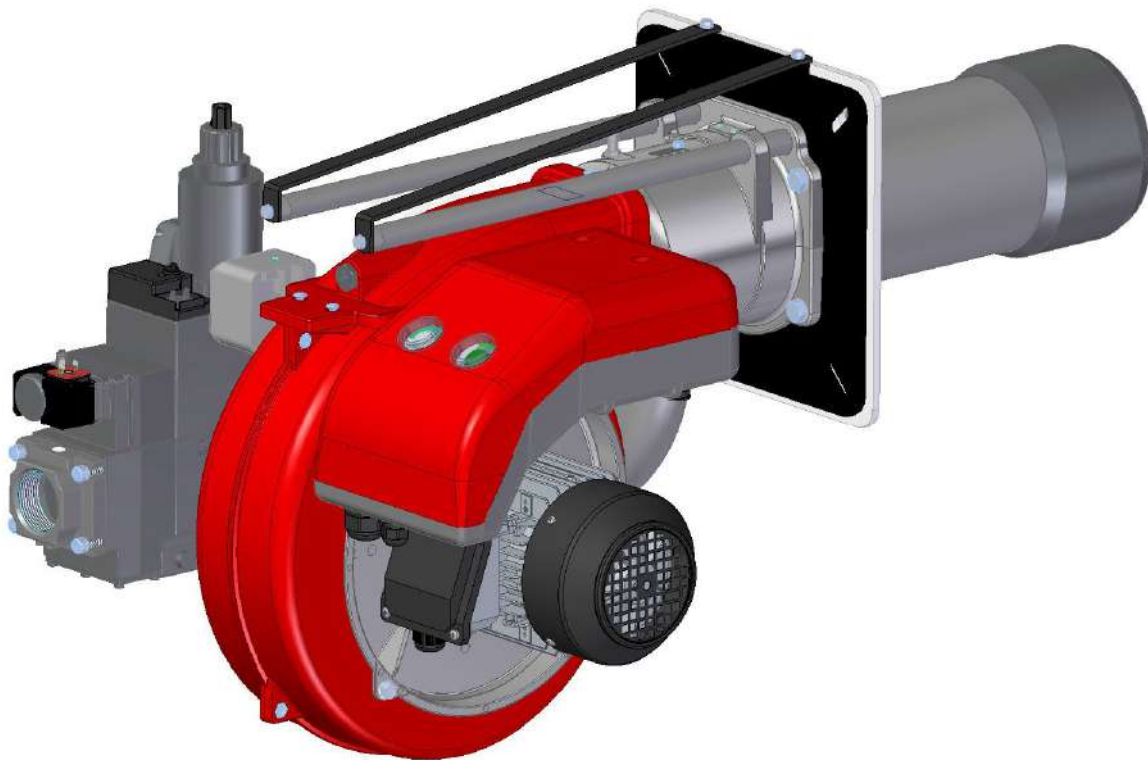

Fig. 1 GAS XP80/2 CE

TECHNICAL DATA AND OPERATING RANGE DIAGRAM XP80/2 CE

| MODEL | GAS XP80/2 CE | |
|---|---|----------------|
| Thermal power min. 1°st. / min. 2°st. - max. 2°st. * | [Mcal/h] | 146/350-731 |
| Thermal power min. 1°st. / min. 2°st. - max. 2°st. * | [kW] | 170/407-850 |
| Gas flow G20 (NATURAL GAS) min. 1°st. / min. 2°st. - max. 2°st. * | [Nm³/h] | 17/40.8-85.3 |
| Gas flow G25 (NATURAL GAS) min. 1°st. / min. 2°st. - max. 2°st. * | [Nm³/h] | 19.8/47.5-99.1 |
| Gas flow G25.3 (NATURAL GAS) min. 1°st. / min. 2°st. - max. 2°st. * | [Nm³/h] | 19.4/46.4-97 |
| Gas flow G31 (L.P.G.) min. 1°st. / min. 2°st. - max. 2°st. * | [Nm³/h] | 6.6/15.8-33 |
| Fuel: NATURAL GAS (second family, G20, G25, G25.3) - L.P.G. (third family, G31) | | |
| Fuel category: | I2R,I2H,I2L,I2E,I2E+,I2Er,I2ELL,I2E(R) I3B/P,I3+,I3P,I3B,I3R | |
| Intermitted working operation (min. 1 stop every 24 hours) two stages | | |
| Environmental conditions operation / storage: | -15...+40°C / -20...+70°C, rel. humidity max. 80% | |
| Max. temperature combustion air | [°C] | 60 |
| Minimum pressure gas train D1"1/4-S NATURAL GAS/L.P.G. ** | [mbar] | 94/53 |
| Minimum pressure gas train D1"1/2-S NATURAL GAS/L.P.G. ** | [mbar] | 24/24 |
| Minimum pressure gas train D2"-S NATURAL GAS/L.P.G. ** | [mbar] | 21/23 |
| Maximum pressure at the entry of valves (Pe. max) | [mbar] | 360 |
| Nominal electric power | [kW] | 1.7 |
| Fan motor | [kW] | 1.5 |
| Nominal motor current absorption | [A] | 3.1 |
| Nominal auxiliary absorption | [A] | 0.7 |
| Power supply: | 3~400V, 1/N~230V-50Hz | |
| Electric protection degree: | IP 40 | |
| NOx Class, NATURAL GAS (second family) | 1 | |
| NOx Class, L.P.G. (third family) | 2 | |
| Noisiness *** min. - max. | [dB(A)] | 79-82 |
| Burner weight **** | [kg] | 43 |

* Reference conditions: Environment temperature 20°C - Barometric pressure 1013 mbars - Altitude 0 metre (sea level).

** Minimal feeding-gas pressure to the gas train to get the maximum power of the burner, considering counter-pressure in combustion chamber of value 0 (zero).

*** Measured sonorous pressure in the laboratory combustion, with functional burner on beta boiler to 1 metre of distance (UNI EN ISO 3746 law - Control method class 3 - The measured sound pressure tolerance can be assumed to be ± 1 [dB (A)]).

**** For burner with long head add 2 kg to the weight.

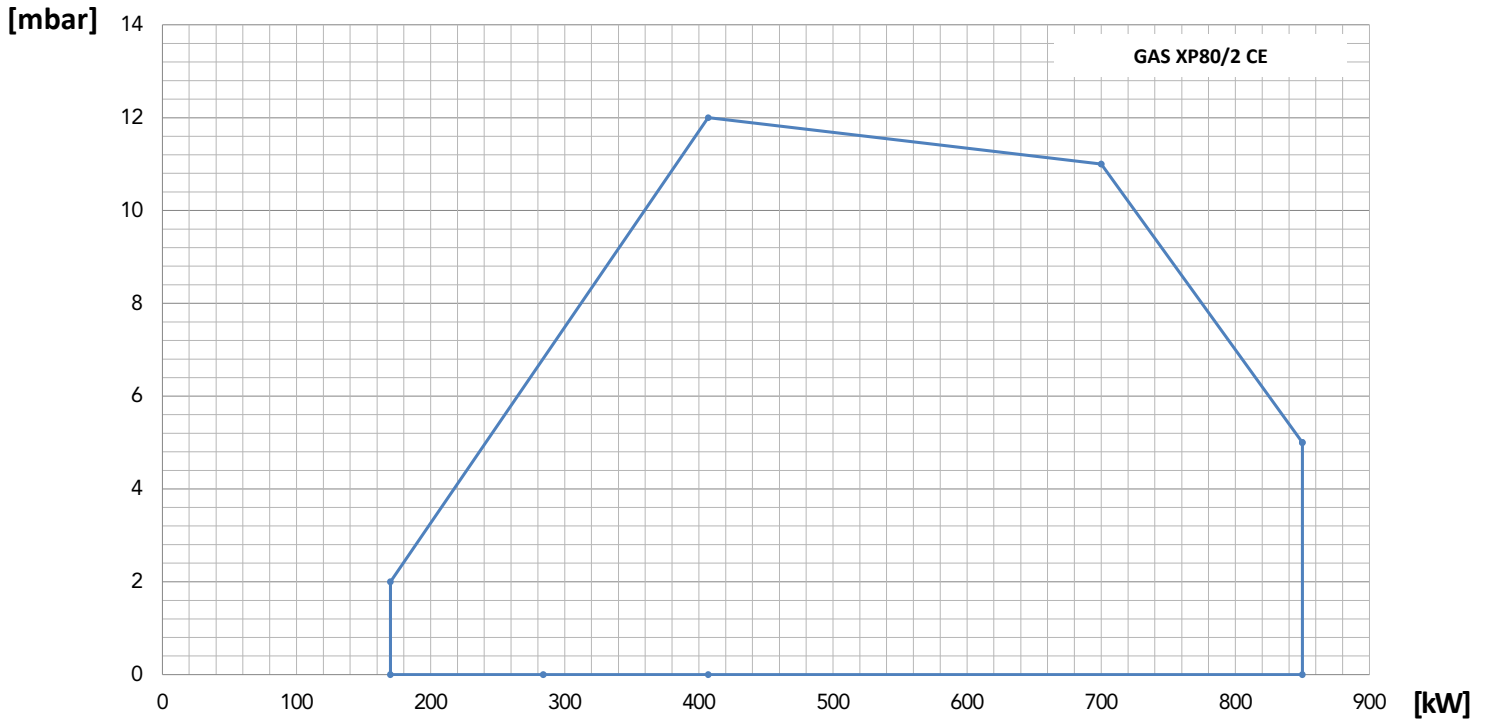

The firing rates has been obtained based on test boilers in accordance with EN267 standards and are indicative of matching the burner to the boiler. For the correct operation of the burner, combustion chamber dimensions must be in accordance with current regulation. In case of non-compliance, contact the manufacturer.

DIMENSIONS [MM]

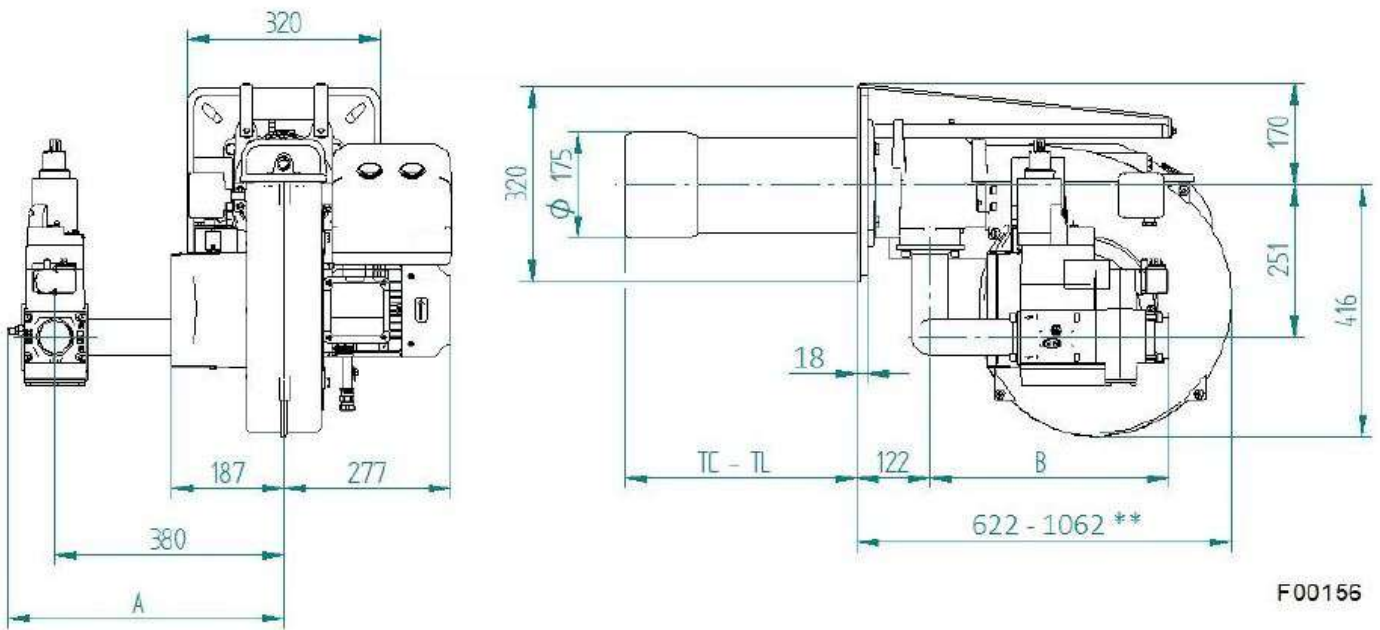

Fig. 3 Dimensions

| GAS TRAIN | A | B |
|-----------|-----|------|
| D1"1/4-S | 437 | 382* |
| D1"1/2-S | 458 | 396 |
| D2"-S | 458 | 396 |

* Includes length of 66 mm due to adapter code 057020

** Overall dimension with the burner out in position of maintenance.

TC - TL: Please see chapter "Flame tube length"

BOILER PLATE

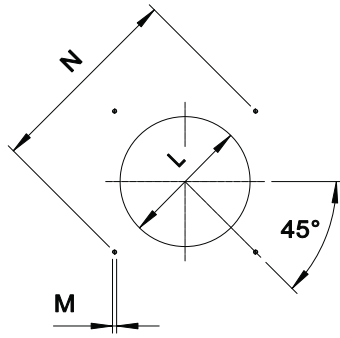

The dimensions of the boiler plate must be as indicated in the drawing.

* Suggested dimension of connection between burner and generator.

| MODEL | | L min | L* | L max | M | N min | N max |
|---------------|----|-------|-----|-------|-----|-------|-------|
| GAS XP80/2 CE | mm | 185 | 185 | 250 | M12 | 310 | 365 |

FLAME TUBE LENGTH

Flame tube length must be selected based on the specifications supplied by boiler manufacturer and, in any case, it must be greater than the thickness of the boiler door included its insulation.

In case of boilers with flame inversion or front flue combustion chambers, it is necessary to insulate the area between the flame tube and front door with refractory material. This protection material must not impede flame tube extraction.

| FLAME TUBE LENGTH | | |
|-------------------|----|--------|
| TC | mm | 250 |
| TL | mm | 385 ** |

** For different flame lengths, please contact our Technical-Sales Department.

BURNER SIGNAL DESCRIPTION

In the picture below there are indicated all the signalation present on the burner:

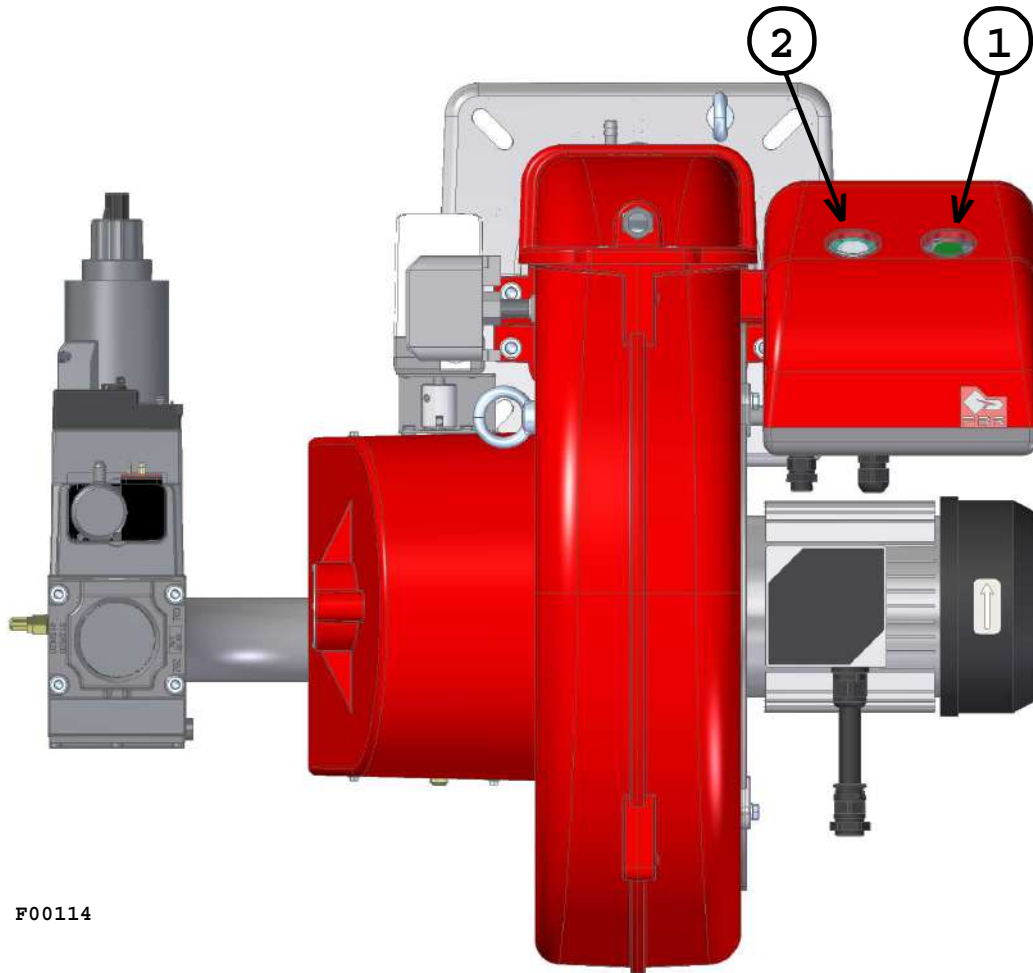

F00114

Fig. 4 Burner signal description

LEGEND

- 1) ON/OFF button
- 2) Reset from lockout button + status lamp

💡 The multicolor signal lamp in the lockout reset button (pos.2) is the key indicating element for visual diagnostics and interface diagnostics.
In normal operation, the different operating states are indicated in the form of color codes; please refer to electrical device handbook supplied with the present instructions.

💡 After a non-alterable lockout, the red signal lamp in the lockout reset button (pos.2) lights up.
By pressing the lockout reset button (pos.2) for more than 3 seconds, the visual diagnostics of the cause of fault can be activated; please refer to electrical device handbook supplied with the present instructions.

For close the diagnostics mode and for switch on the burner again, it is necessary to reset the burner control. Press the lockout reset button (pos.2) for about 1 second (<3 seconds).

💡 After a non-alterable lockout, the red signal lamp in the lockout reset button (pos.2) lights up.
For reset the control box press the lockout reset button (pos.2) for about 1 second (<3 seconds).

PRODUCT SPECIFICATION**SHORT DESCRIPTION**

Gas burners two stages.

DETAILED SPECIFICATION

Gas burner two stages composed by:

- Aluminum body;
- Fan at high pressurisation;
- Combustion head with adjustment at high performance and elevated flame stability equipped with inox steel blast tube and inox steel flame disc;
- Flange and insulating gasket for fixing at boiler;
- Three-phase power supply;
- Safety air pressure switch to stop the burner in lock-out in case of failed or anomalous fan operation;
- Gas train with safety valve class A, adjustment two stages valve class A;
- Optional valve proving system;
- Ionisation probe for flame detection;
- IP 40 electric protection level;
- Servomotor for air shutter and for the consent of the 2nd stage gas valve;
- Moving shutter with total closure when idle in order to reduce at the least energy losses related to boiler cooling down;
- Supports and tierods for burner extraction.

CONFORMING TO:

- CE rules;
- 2014/30/UE Directive E.M.C.;
- 2014/35/UE Directive L.V.;
- 2006/42/CE - 2006/42/EG - 2006/42/EC Directive M.D.;
- GAS 2016/426/UE Regulation;
- Reference rules: EN676 (gas) – EN 746-2 (industrial thermoprocessing equipment).

STANDARD EQUIPMENT

- Isomart gasket;
- Flange with insulating gasket;
- Burner nameplate;
- Warranty;
- Instruction handbook for installation, use and maintenance.

OPTIONAL

- Noise protection;
- Antivibration couplings;
- Handle gas taps.