

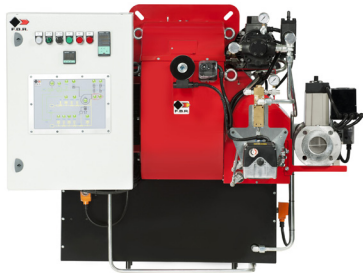

FBR
BURNERS MADE IN ITALY



DUAL FUEL BURNER _ GAS/HEAVY OIL SERIE KN

Progressive and modulating from 1390 up to 6395 kW

Dual fuel burners for gas and heavy oil at 2 stages progressive (hi-low flame) or PID fully modulating if optional modulation kit (digital type) and feeder (of temperature or pressure) are added.

Fan at high pressurization, high efficiency combustion head with adjustment and high flame stability, pilot flame for gas ignition.

Available versions for natural gas or LPG (to be specified in your order).

Gas train includes working valve, safety valve, minimum gas pressure switch, gas pressure filter-stabilizer and is supplied already assembled, connected and tested.

The adoption of strong metal components makes the burner durable also in heavy duty conditions.

Burners are supplied with nozzle, fuel switch, gasket for installation on boiler, flexible hoses, pre-heated line filter and thermostat, pre-heating tank with low density flanged resistances and degaser tank.

TECHNICAL DATA

MODEL		KN 350/M	KN 450/M	KN 550/M
Thermal power min-max*	Mcal/h	400/1200-3500	500/1600-4500	600/200-5500
	kW	464/1390-4060	580/1850-5220	696/2325-6395
Flow-rate G20 (NATURAL GAS) min-max*	Nm ³ /h	47/140-409	58/187-526	70/235-647
Flow-rate G31 (LPG) min-max*	Nm ³ /h	18/54-158	22/72-203	27/91-250
Fuel		NATURAL GAS (second family) - LPG (third family)		
Combustible category		2R' 2H' 2L' 2E' 2E+ 2Er' 2ELL' 2E(R)B 38/P' 3+ 3P' 38' 3R		
Intermittent operation (min. 1 stop every 24 hours) at 2 stages progressive or modulating				
Allowed environment conditions on running/stock		-15...+40°C/-20...+70°C, rel. humidity max 80%		
Max temperature combustion air	°C	60	60	60
Min. pressure gas train D2"-FS50 NATURAL GAS/LPG**	mbar	294/143	490/237	-/354
Min. pressure gas train DN65-FS65 NATURAL GAS/LPG*	mbar	145/90	222/143	313/195
Min. pressure gas train DN80-FS80 NATURAL GAS/LPG**	mbar	90/70	144/109	200/146
Min. pressure gas train DN100-FS100 NATURAL GAS/LPG**	mbar	57/57	87/87	112/112
Max pressure at the entry of the valves (Pe.max)	mbar	500	500	500
HEAVY-OIL flow-rate min-max*	kg/h	40/120-350	50/160-450	60/200-550
Fuel		HEAVY OIL 5°-20° E to 50° C		
Nominal electric power	kW	37.5	46	57
Motor fan	kW	9.2	11	18.5
Motor pump	kW	2.2	2.2	2.2
Resistances	kW	24	30	36
Nominal absorption power	A	23	28	37
Nominal absorption auxiliary	A	0.5	0.5	0.5
Nominal absorption resistances	A	37	46	57
Power supply		3~400V,1/N~230V-50Hz		
Degree of electric protection		IP40	IP40	IP40
Noisiness***min-max	dB(A)	84-85	85-88	87-91
Burner weight	kg	274	306	341

* Reference conditions: Room temperature 20°C - Atmospheric pressure 1013 mbars - Altitude 0m (sea level)

** Least pressure of feeding of the gas to the train to get the maximum power of the burner considering against pressure in chamber of value combustion 0 (zero)

*** Measured sonorous pressure in the laboratory combustion, with functional burner on beta boiler to 1 m of distance (UNI EN ISO 3746 law)

FIRING RATES: Thermal power - Pressure in combustion chamber

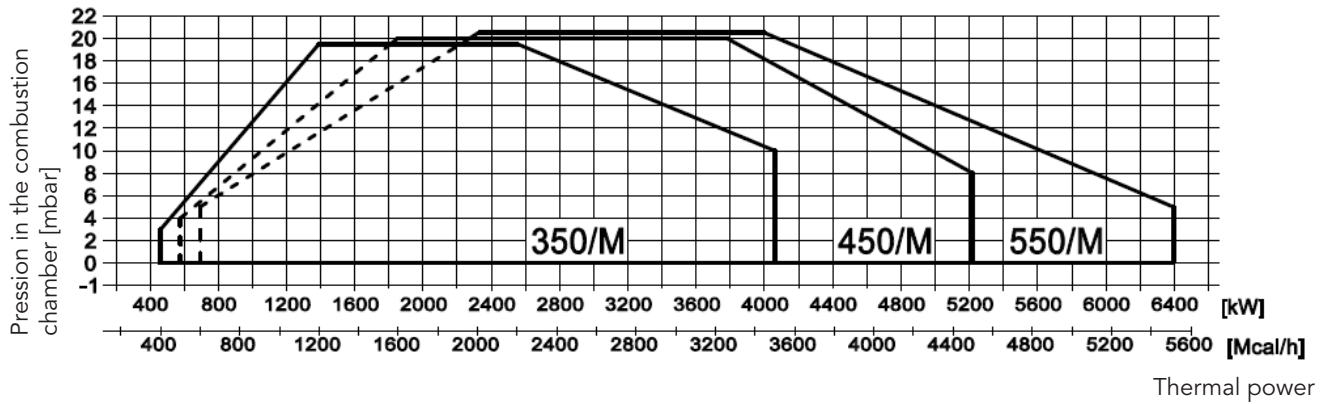

DIMENSIONS (mm)

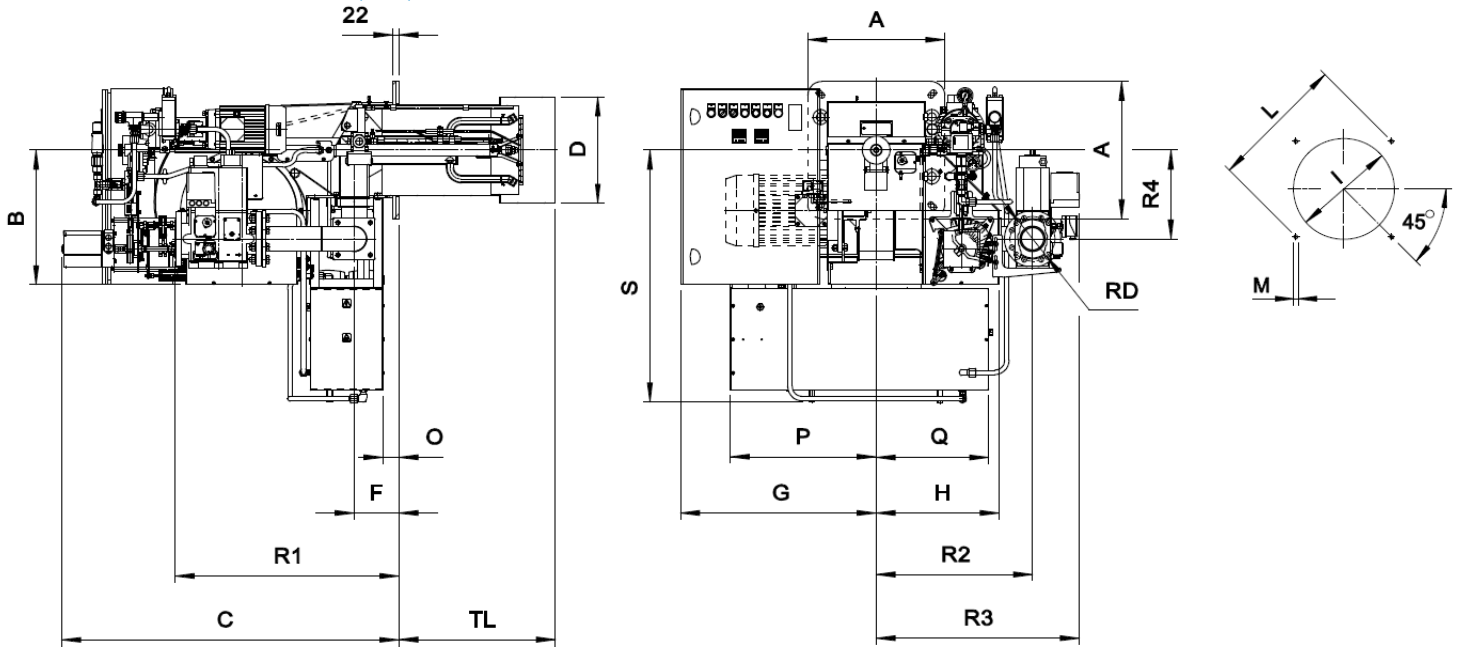

* Suggested dimension of connection between burner and generator

MODEL	A	B	C	D	F	G	H	TL	I min	I*	I max	M	L min	L*	L max	O	P	Q	S	R1	R2	R3	R4	RD	Gas train weight
KN 350/M - D2"	490	481	1206	334	160	700	440	535	350	350	450	M14	552	552	580	57	523	405	762	570	535	648	317	D2"	22 kg
KN 350/M - DN65 - FS65	490	481	1206	334	160	700	440	535	350	350	450	M14	552	552	580	57	523	405	762	780	560	713	317	DN65	37 kg
KN 350/M - DN80 - FS80	490	481	1206	334	160	700	440	535	350	350	450	M14	552	552	580	57	523	405	762	800	560	726	317	DN80	47 kg
KN 350/M - DN100 - FS100	490	481	1206	334	160	700	440	535	350	350	450	M14	552	552	580	57	523	405	762	840	590	764	317	DN100	57 kg
KN 450/M - D2"	490	481	1206	380	160	700	440	560	390	390	450	M14	552	552	580	57	523	405	905	570	535	648	317	D2"	22 kg
KN 450/M - DN65 - FS65	490	481	1206	380	160	700	440	560	390	390	450	M14	552	552	580	57	523	405	905	780	560	713	317	DN65	37 kg
KN 450/M - DN80 - FS80	490	481	1206	380	160	700	440	560	390	390	450	M14	552	552	580	57	523	405	905	800	560	726	317	DN80	47 kg
KN 450/M - DN100 - FS100	490	481	1206	380	160	700	440	560	390	390	450	M14	552	552	580	57	523	405	905	840	590	764	317	DN100	57 kg
KN 550/M - D2"	490	481	1206	380	160	700	440	560	390	410	450	M14	552	552	580	57	523	405	905	570	535	648	317	D2"	22 kg
KN 550/M - DN65 - FS65	490	481	1206	380	160	700	440	560	390	410	450	M14	552	552	580	57	523	405	905	780	560	713	317	DN65	37 kg
KN 550/M - DN80 - FS80	490	481	1206	380	160	700	440	560	390	410	450	M14	552	552	580	57	523	405	905	800	560	726	317	DN80	47 kg
KN 550/M - DN100 - FS100	490	481	1206	380	160	700	440	560	390	410	450	M14	552	552	580	57	523	405	905	840	590	764	317	DN100	57 kg