

BURNERS FOR HEAVY OIL/LOW FLAME (2 STAGES PROGRESSIVE) OR PID FULLY MODULATING



Burners for heavy oil hi/low flame (two stages progressive) or PID fully modulating with the addition of the optional modulation kit (digital) and feeder (of temperature or pressure). Fan at high pressurization, combustion head high efficiency and high flame stability, servomotor for the balanced adjustment of air and oil flow.

Rationalized disposition of the components with easy access for the settings and maintenance operations.

The adoption of strong components assure long durability also in heavy duty conditions. Supplied complete of nozzle, preheating tank with specific low charge electrical resistances and filter, gasket for installation on boiler, flexible hoses, line filter heated and complete with thermostat and degaser tank.

TECHNICAL DATA

MODEL		FNDP 70/M	FNDP 100/M	FNDP 125/M	FNDP 150/M
Flow-rate *	Kg/h	18/35-70	20,5/40-100	29/60-125	38,5/75-150
Heat output *	Mcal/h	176/343-686	201/392-980	284/588-1225	377/735-1470
Heat output *	kW	204/398-796	233/455-1137	330/682-1421	437/853-1705
Motor	kW	2,2	2,2	3	4
Maximum absorbed power	kW	9,5	12,7	14,2	16,2
Fuel	HEAVY OIL 5°-20° E A 50°C				
Electrical supply	3/N~400/230V-1/N~230V-50Hz		3~400V-1/N~230V-50Hz		
Electrical protection	IP40				

* Reference conditions: Room temperature 20°C - Atmospheric pressure 1013 mbars - Altitude 0 (sea level).

FIRING RATES: Heat output – Combustion chamber pressure

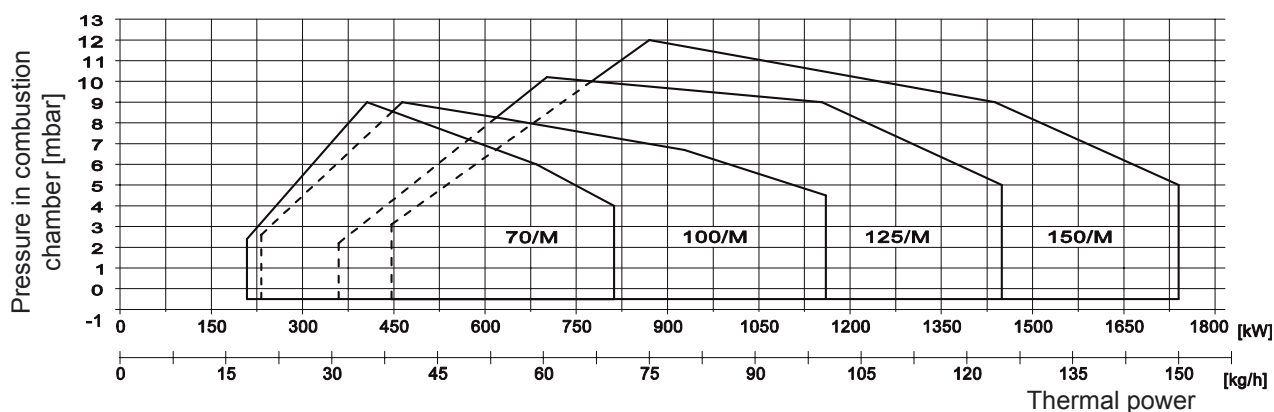

OVERALL DIMENSIONS (mm.)

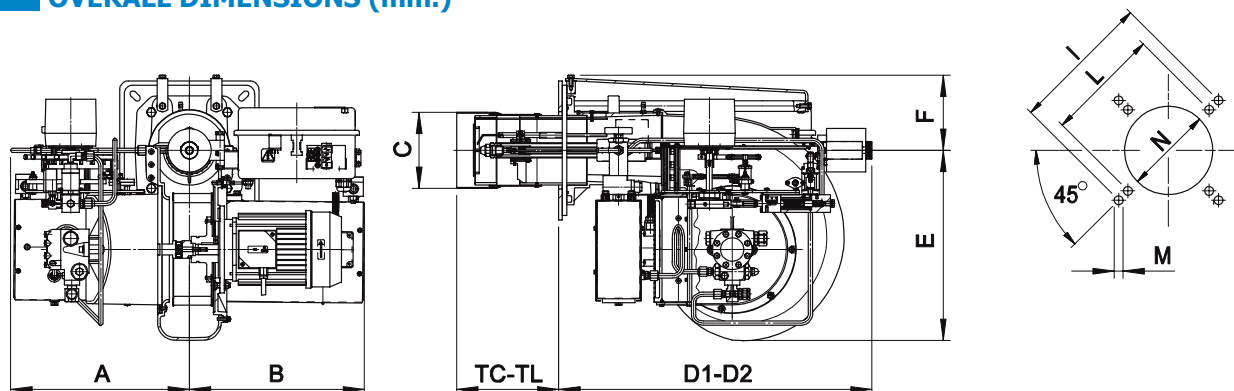

D2= I block to rear burner in maintenance position.

MODEL	A	B	C	D1	D2	E	F	TC	TL	I	L	M	N
FNDP 70/M	360	385	165	735	1175	355	171	250	350	368	340	M12	180
FNDP 100/M	410	400	175	720	1150	440	173	235	335	368	340	M12	200
FNDP 125/M	420	400	209	860	1440	520	213	200	400	368	340	M14	230
FNDP 150/M	420	400	209	860	1440	520	213	200	400	368	340	M14	230