

FNDP 750-1000-1300-1500-1800/M-EL

ELECTRONIC MODULATION

Heavy oil burners at 2 stages progressive (hi-low flame) or modulating (PID fully modulating) if equipped with modulation kit and probe.

Equipped with Lamtec BT3 electronic camme. Fan at high pressurization, high efficiency combustion head with adjustment and high flame stability, pump, multistage preheating tank and degaser skid. Suitable for heavy oil up to 50°E to 50°C and for BTZ heavy oil.

Rational disposal of components with easy accessibility for calibration and maintenance operations.

The adoption of strong metal components makes the burner durable also in heavy duty conditions.

Burners are supplied with nozzle, gasket for installation on boiler, flexible hoses, line filter.

The burners are equipped with an operating display that allows:

- Adjustment of the parameters of the burner operation
- Adjustment of the setpoint and operation range of the pressure / temperature probe
- Adjustment of the burner's curveset

With the addition of optional accessories (probes) thanks to the most advanced systems for automatic modulation, the burner constantly ensures with PID control the proper power to achieve and maintain the set point. The maximum efficiency of the returns in each combustion point derived from the punctual adaptation of the thermal load to the heat requirements of the burner at any instant of operation.

The fuel /combustion air curve, more extended, is fully exploited, guaranteeing excellent performance in terms of accuracy and speed, even during the calibration phase. A microprocessor monitors the different stages of the process and allows the correct repetition of the sequences of operation.

Optional accessories: PC interface, VSD (inverter), O2 control, O2+CO control, field bus (profibus, modbus, profinet).



Pump skid



Degaser

Motor 1400 rpm

Multistage pre-heating tank with specific flanged heaters

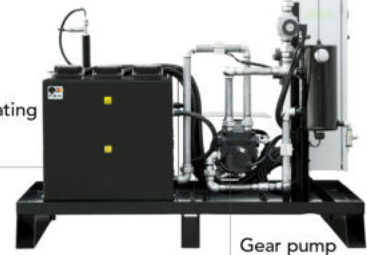

Gear pump

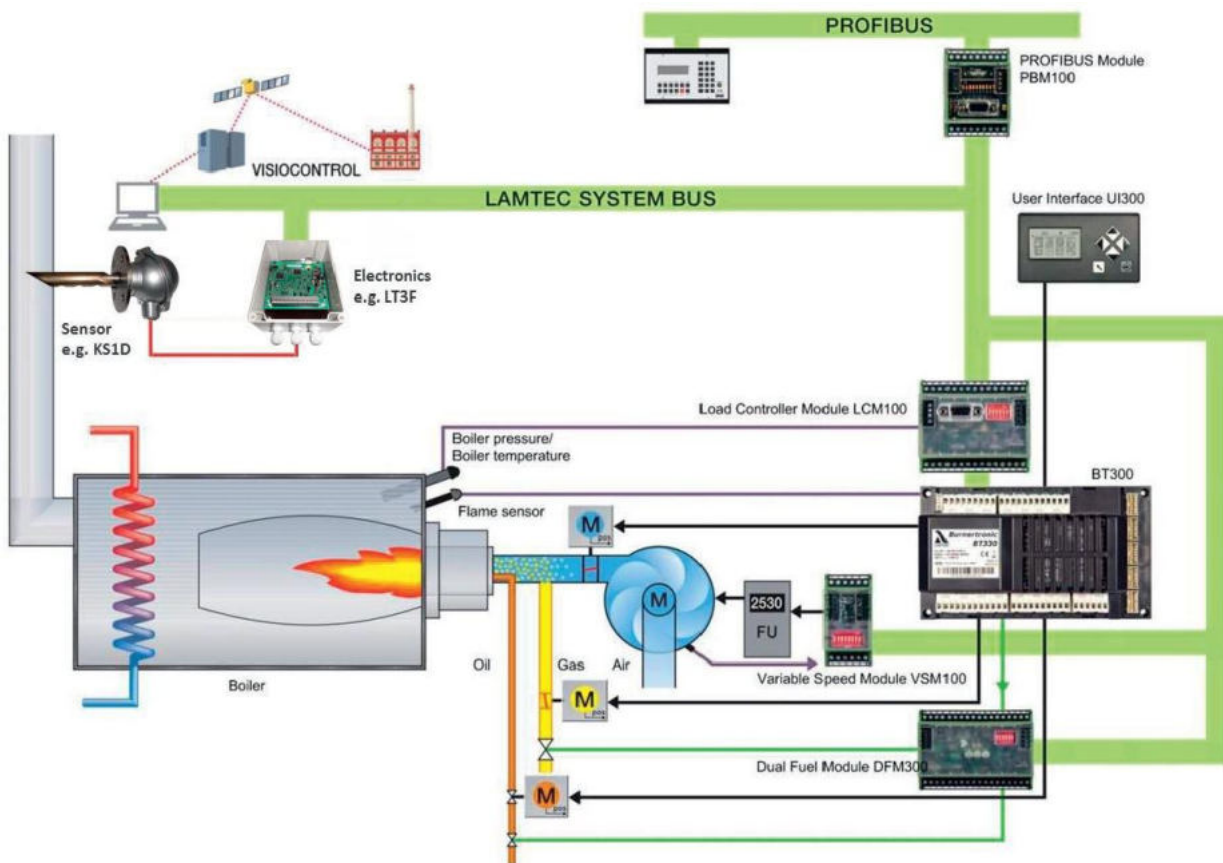

TECHNICAL DATA

MODEL		FNDP 750/M-EL	FNDP 1000/M-EL	FNDP 1300/M-EL
Thermal power min 1°st./min 2°st.-max 2°st. *	[Mcal/h]	1200/3400-7500	1200/3400-10000	1700/3600-11500
Thermal power min 1°st./min 2°st.-max 2°st. *	[kW]	1395/3953-8721	1395/3953-11628	1977/4186-13372
HEAVY-OIL flow min 1°st./min 2°st.-max 2°st. *	[kg/h]	122-347-765	122/347-1020	173/367-1173
Fuel		Heavy-oil 5° -50°E at 50°C		
Intermittent working operation (min, 1 stop every 24 hours) two stages progressive or modulating				
Enviromental conditions operation/storage		-15...+40°C / -20...+70°C ,relative humidity max. 80%		
Max temperature combustion air	[°C]	60	60	60
Nominal electric power	[kW]	25.5	34.5	41.5
Fan motor	[kW]	22	30	37
Pump motor	[kW]	3	4	4
Power supply		3~400V-1/N~230V-50Hz	3~400V-1/N~230V-50Hz	3~400V-1/N~230V-50Hz
Degree of electric protection		IP40	IP40	IP40
Noisiness**max	[dB(A)]	89	91	93

* Reference conditions: Environment temperature 20°C - Barometric pressure 1013 mbars - Altitude 0 metre (sea level).

** Measured sonorous pressure in the laboratory combustion, with functional burner on beta boiler to 1 metre of distance (UNI EN ISO 3746 law).

FIRING RATES

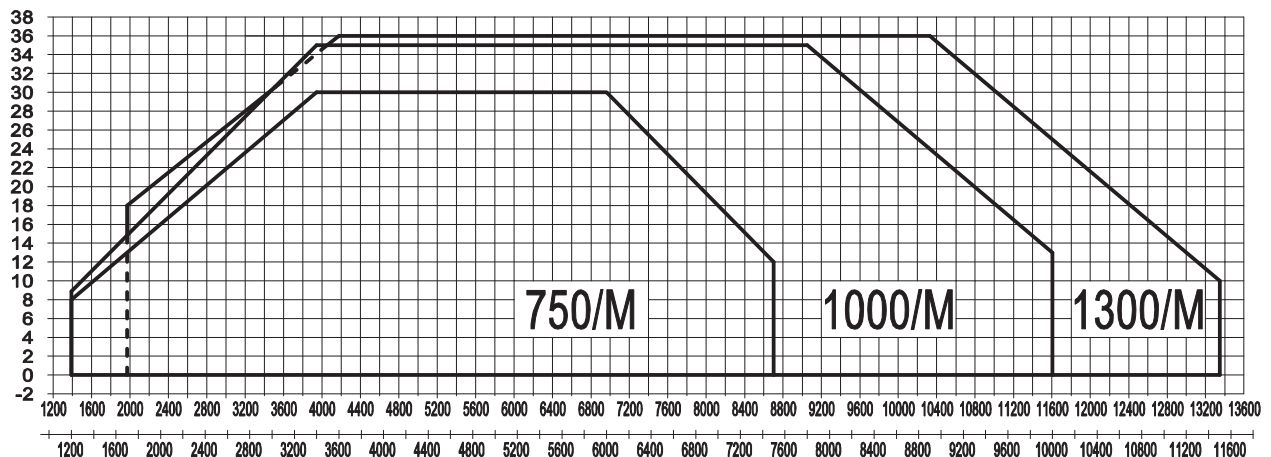

Fig. 2 X = Thermal power (kW - Mcal/h) Y = Pression in the combustion chamber (mbar)

The firing rates has been obtained based on test boilers in accordance with EN267 standards and are indicative of matching the burner to the boiler. For the correct operation of the burner, combustion chamber dimensions must be in accordance with current regulation. In case of non-compliance, contact the manufacturer.

TECHNICAL DATA

MODEL		FNDP 1500/M-EL	FNDP 1800/M-EL
Thermal power min 1°st./min 2°st.-max 2°st. *	[Mcal/h]	1700/3600-13000	2000/5000-15000
Thermal power min 1°st./min 2°st.-max 2°st. *	[kW]	1977/4186-15116	2325/5815-17442
HEAVY-OIL flow min 1°st./min 2°st.-max 2°st. *	[kg/h]	173/367-1326	204-510-1531
Fuel		Heavy-oil 5° -50°E at 50°C	
Intermittent working operation (min, 1 stop every 24 hours) two stages progressive or modulating			
Enviromental conditions operation/storage		-15...+40°C / -20...+70°C ,relative humidity max. 80%	
Max temperature combustion air	[°C]	60	60
Nominal electric power	[kW]	49.5	61
Fan motor	[kW]	45	55
Pump motor	[kW]	4	5.5
Power supply		3~400V-1/N~230V-50Hz	3~400V-1/N~230V-50Hz
Degree of electric protection		IP40	IP40
Noisiness**max	[dB(A)]	97	101

* Reference conditions: Environment temperature 20°C - Barometric pressure 1013 mbars - Altitude 0 metre (sea level).

** Measured sonorous pressure in the laboratory combustion, with functional burner on beta boiler to 1 metre of distance (UNI EN ISO 3746 law).

FIRING RATES

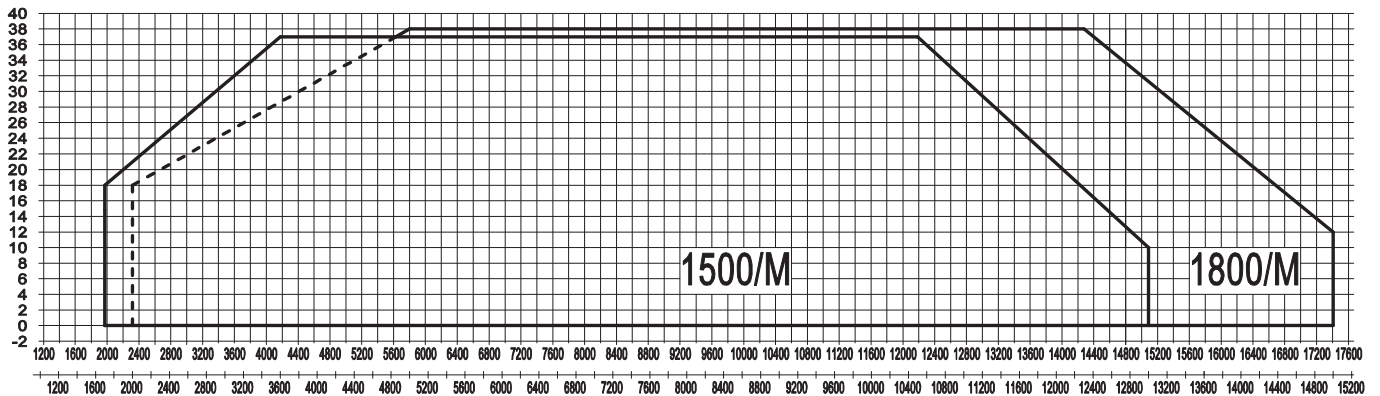
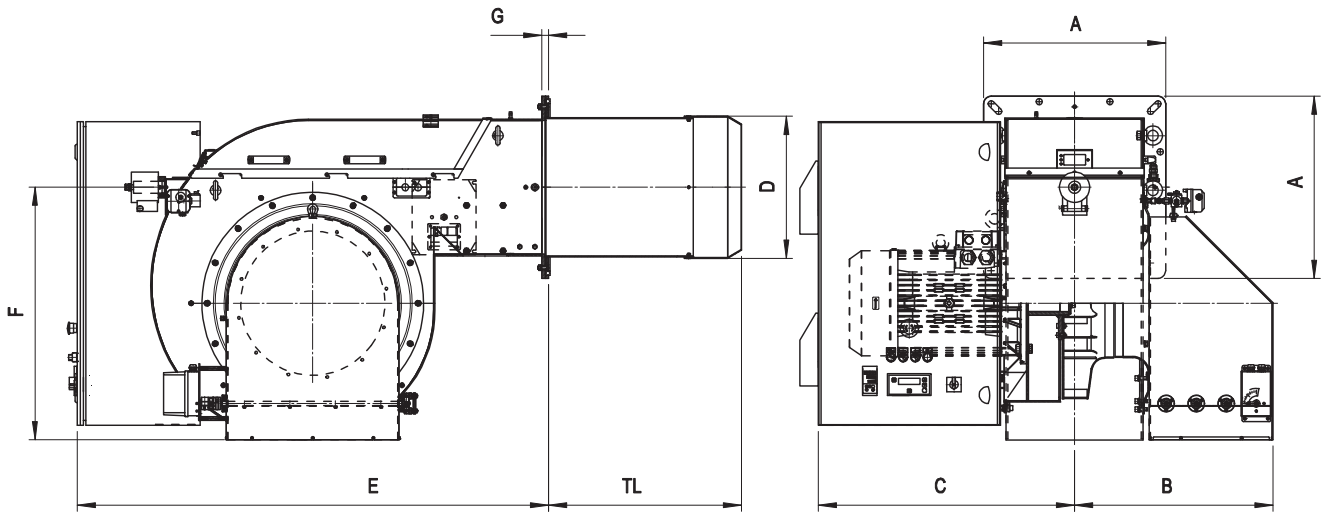

Fig. 3 X = Thermal power (kW - Mcal/h) Y = Pressure in the combustion chamber (mbar)

The firing rates has been obtained based on test boilers in accordance with EN267 standards and are indicative of matching the burner to the boiler. For the correct operation of the burner, combustion chamber dimensions must be in accordance with current regulation. In case of non-compliance, contact the manufacturer.

DIMENSIONS [mm]



MODEL	A	B	C	D	E	F	G	TL
FNDP 750/M-EL	600	832	1508	448	845	654	22	685
FNDP 1000/M-EL	600	832	1508	468	845	654	22	685
FNDP 1300/M-EL	600	832	1508	499	845	634	22	655
FNDP 1500/M-EL	600	832	1508	499	845	634	22	655
FNDP 1800/M-EL	700	884	1660	540	875	680	22	685

BOILER PLATE

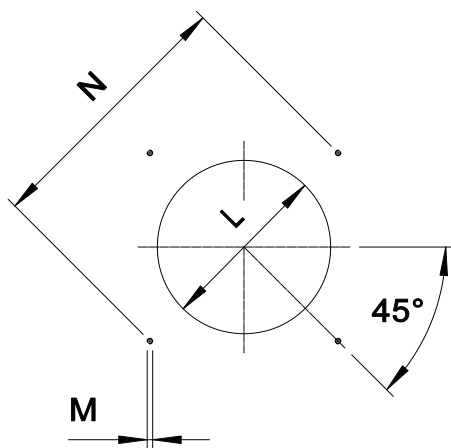

The dimensions of the boiler plate (threaded holes or studs) must be as indicated in the drawing.

MODEL		M	N min	N*	N Max	Lmin	Lmax
FNDP 750/M-EL	mm	M16	707	778	778	460	540
FNDP 1000/M-EL	mm	M16	707	778	778	480	540
FNDP 1300/M-EL	mm	M16	707	778	778	510	540
FNDP 1500/M-EL	mm	M16	707	778	778	510	540
FNDP 1800/M-EL	mm	M18	806	890	890	550	630

* Suggested dimension

PUMP SKID: DIMENSIONS (mm)

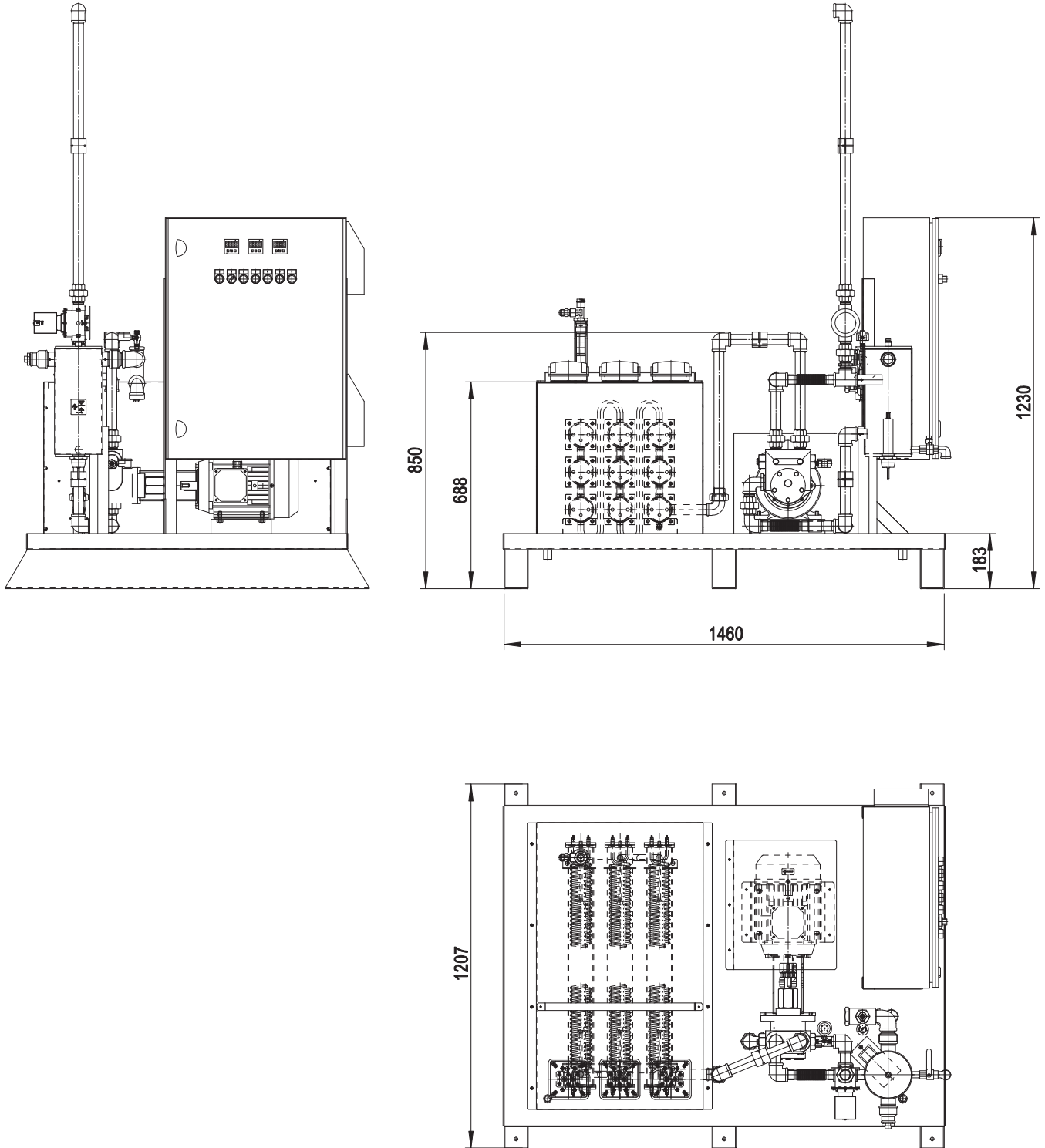

PRODUCT SPECIFICATION**SHORT DESCRIPTION**

Heavy oil burners at 2 stages progressive (hi-low flame) or PID fully modulating if equipped with modulation kit and probe. Available versions for heavy oil up to 50°E to 50°C and ecological heavy oil BTZ (low sulfur oil).

DETAILED SPECIFICATION

Heavy oil burners from 5 to 50°E at 50°C, 2 stages progressive (hi-low flame), with possibility of modulating working (PID fully modulating with optional modulation kit and probe). The burner is composed by:

- Burner frame made of steel completed by specific boiler plate;
- Centrifugal fan at high pressurization with reverse curved blades at low noisiness;
- Combustion head with adjustment at high performance and elevated flame stability equipped with steel blast tube and steel flame disc;
- Easy extraction of combustion head without get off the burners by bolier;
- Combustible-air adjustment for optimal combustion value;
- Flange and insulating gasket for fixing at boiler/furnace;
- PID regulators for the control of fuel heaters;
- Electronic control system for controlling and command the burner LAMTEC BT3;
- UV Photocell for flame detection;
- Three-phase power supply;
- Fan motor start-up made by softstart system (on model FNDP 1300-1500-1800/M-EL);
- IP40 electric protection level;
- Safety air pressure switch to stop the burner in case of failed or anomalous fan operation;
- Maximum oil pressure switch to stop the burner in case of the oil pressure on the return is higher then the set point value;
- Servomotor for air shutter;
- Mobile shutter with total closure when idle for minimize the energetic losses related at boiler cooling;
- Servomotor for heavy oil adjust;
- Heavy oil gear pump operated by specific electric motor;
- Thermocouples for detecting the oil temperature;
- Button for the manual tank load;
- Multistage pre-heating tank with specific flanged heaters at low density (anticracking and antigas);
- Resistances (always on) for pump, nozzle and fuel valve;
- Pressure manometer on inlet pump;
- Thermometer inside pre-heating tank for temperature heavy-oil;
- Nozzle assembly with magnet to control inlet/return needle nozzle;
- Double filter between pump and nozzle;
- Set up for the additional specific kit that transforms burner operation as modulating i.e.the modulating kit allows to supply any power between the minimum and maximum value based on instantaneous loading request.

CONFORMING TO:

- CE rules;
- 2014/30/UE Directive E.M.C.;
- 2014/35/UE Directive L.V.;
- 2006/42/CE - 2006/42/EG - 2006/42/EC Directive M.D.;
- Reference rules: EN267(liquid fuel) - EN746-2 (industrial thermoprocessing equipment)

STANDARD EQUIPMENT

- Flexible pipes for connection
- Line filter
- Isomart gasket
- Nozzle
- Flange with insulating gasket
- Burner nameplate
- Warranty
- Instruction handbook for installation, use and maintenance

OPTIONAL

- Power modulating kits for temperatures;
- Power modulating kits for pressures;
- Kit for input 4-20mA / 0-10Vdc;
- Temperature probe 0°C-400°C (PT 100 a 0° C);
- Temperature probe 0°C-350°C (J probe);
- Temperature probe 0°C-1200°C (K probe);
- Pressure probe 0-3 bar, 0-6 bar, 0-16 bar, 0-20 bar, 0-30 bar;
- Sensors and system for O₂ control (is suggest to add the VSD);
- Sensors and system for CO control (is suggest to add the VSD);
- Sensors and system for O₂-CO control (is suggest to add the VSD);
- Modules for field BUS (modbus - profibus - profinet);
- Noise protection