

K 5/2 - K 6/2 - K 7/2

Dual fuel gas/light-oil burners at two stages.

They are composed by: aluminium frame, fan at high pressurisation and combustion head with adjustment at high efficiency and high flame stability.

Compact overall dimensions and disposition rationalized of the components with accessibility facilitated for the operations of setting and maintenance.

Available in the versions METHANE (natural gas) or L.P.G. (to specify at the order) on demand specific versions for town gas, coal gas or biogas.

For models K 5/2 - K 6/2; gas train complete of: one-block valve class A (1st stage + 2nd stage slow opening + safety), minimum gas pressure switch and filter-stabilizer.

For models K 7/2; gas train complete of: one-block valve class A (1st stage + 2nd stage slow opening + safety), valve proving system, minimum gas pressure switch and filter-stabilizer.

Complete of: flange and gasket for installation on generator, nozzles, flexible pipes and line filter.

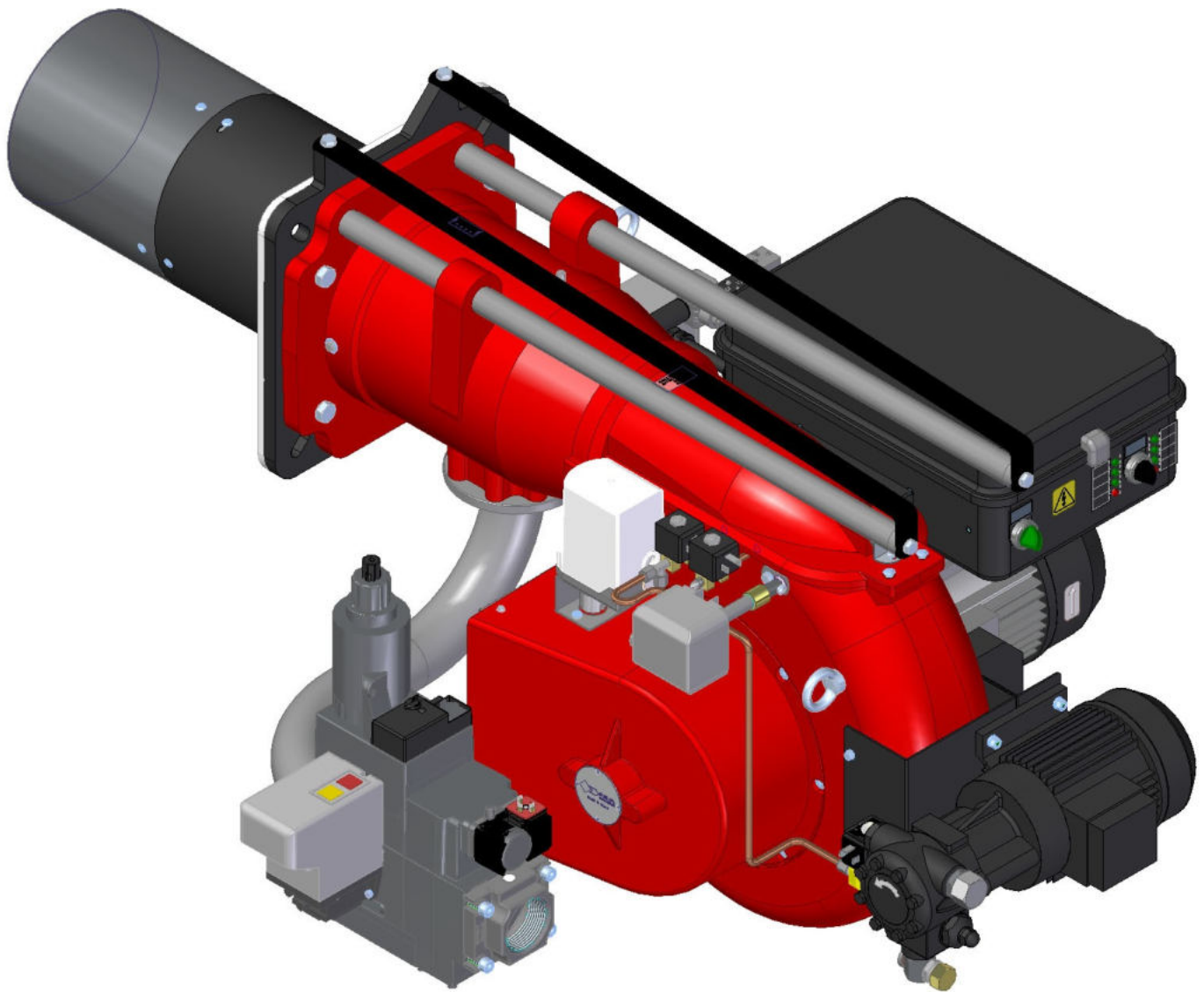

Fig. 1 K 7/2

TECHNICAL DATA AND OPERATING RANGE DIAGRAM K 5/2 - K 6/2 - K 7/2

MODEL		K 5/2	K 6/2	K 7/2
Thermal power 1°st. / min. 2°st. - max. 2°st. *	[Mcal/h]	116/350-650	172/500-1000	258/774-1500
Thermal power 1°st. / min. 2°st. - max. 2°st. *	[kW]	135/406-754	200/581-1162	300/900-1744
Gas flow G20 (NATURAL GAS) 1°st. / min. 2°st. - max. 2°st. *	[Nm³/h]	13.5/41-76	20/58.4-117	30/90.5-175
Gas flow G31 (L.P.G.) 1°st. / min. 2°st. - max. 2°st. *	[Nm³/h]	5.2/15.7-29.3	7.8/22.6-45.2	11.7/35-67.9
Fuel: NATURAL GAS (second family) - L.P.G. (third family)				
Fuel category:		I2R,I2H,I2L,I2E,I2E+,I2Er,I2ELL,I2E(R)/I3B/P,I3+,I3P,I3B,I3R		
Minimum pressure gas train D1" - S NATURAL GAS/LPG **	[mbar]	72/53	-	-
Minimum pressure gas train D1"1/4 - S NATURAL GAS/LPG **	[mbar]	45/34	-	-
Minimum pressure gas train D1"1/2 - S NATURAL GAS/LPG **	[mbar]	28/23	43.8/22.9	84.5/39.5
Minimum pressure gas train D2" - S NATURAL GAS/LPG **	[mbar]	22/21	39/20.9	73/35
Maximum pressure at the entry of valves (Pe. max)	[mbar]	360	360	360
LIGHT-OIL flow 1°st. / min. 2°st. - max. 2°st. *	[kg/h]	11.6/35-65	17.2/50-100	25.8/77.4-150
Fuel: LIGHT-OIL 1,5°E at 20°C= 6,2 cSt = 35 sec Redwood N°1				
Intermittent working operation (min. 1 stop every 24 hours) two stages				
Environmental conditions operation / storage:		-15...+40°C / -20...+70°C, rel. humidity max. 80%		
Max. temperature combustion air	[°C]	60	60	60
Nominal electric power	[kW]	1.5	3.4	3.8
Fan motor	[kW]	1.1	3	3
Nominal absorption fan motor	[A]	2.7	6.4	6.4
Pump motor	[kW]	0.37	0.37	0.74
Nominal absorption pump motor	[A]	1.2	1.2	2
Power supply:		3~400V, 1/N~230V-50Hz		
Electric protection degree:		IP 40	IP 40	IP 40
Noisiness *** min. - max.	[dB(A)]	72-78	83-84	83-84
Burner weight	[kg]	62	95	101

* Reference conditions: Environment temperature 20°C - Barometric pressure 1013 mbars - Altitude 0 metre (sea level).

** Minimal feeding-gas pressure to the gas train to get the maximum power of the burner, considering counter-pressure in combustion chamber of value 0 (zero).

*** Measured sonorous pressure in the laboratory combustion, with functional burner on beta boiler to 1 metre of distance (UNI EN ISO 3746 law).

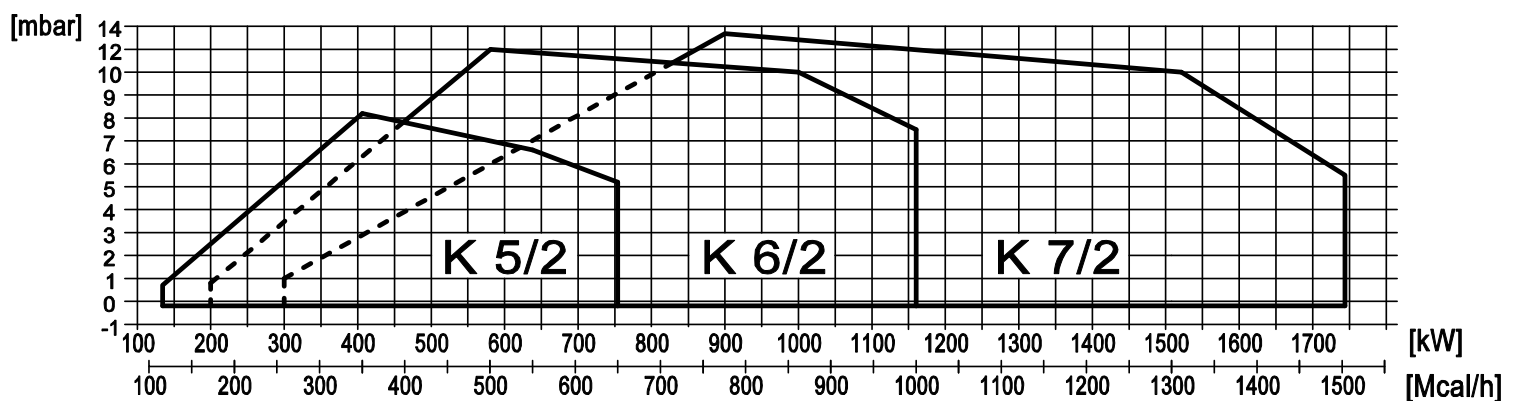

Fig. 2 X = Thermal power Y = pressure in combustion chamber

The firing rates has been obtained based on test boilers in accordance with EN267 standards and are indicative of matching the burner to the boiler. For the correct operation of the burner, combustion chamber dimensions must be in accordance with current regulation. In case of non-compliance, contact the manufacturer.

DIMENSIONS [MM]

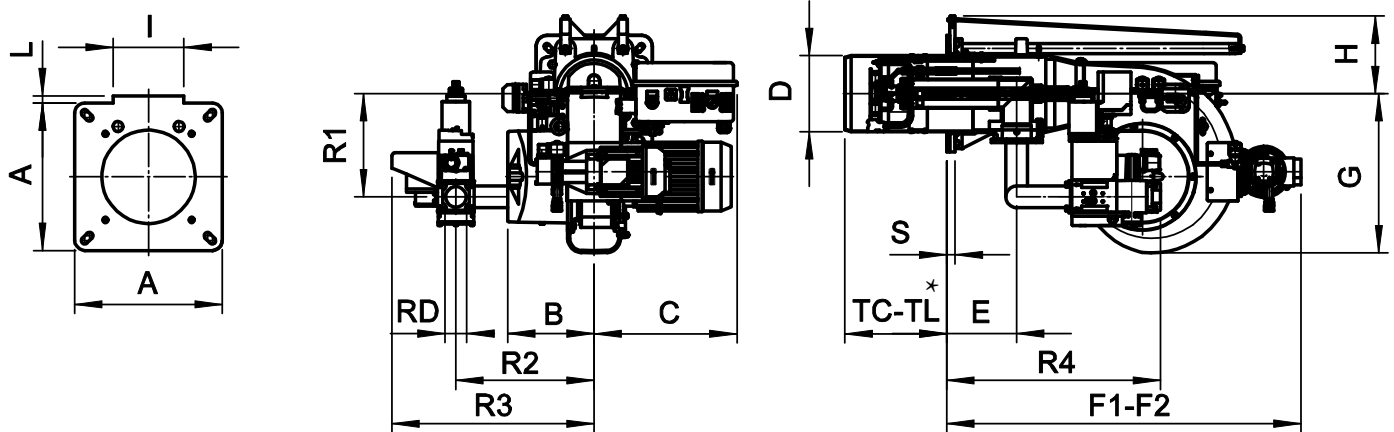

Fig. 3 Dimensions: K 5/2 - K 6/2 - K 7/2

MODEL	A	B	C	D	E	F1	F2*	G	H	I	L	S	R1	R2	R3	R4	RD	Gas train weight
K 5/2 - D1"-S	300	236	365	175	168	840	1280	327	171	144	10	18	260	380	438	548	Rp1	23 kg
K 5/2 - D1"1/4-S	300	236	365	175	168	840	1280	327	171	144	10	18	260	380	438	548	Rp 1 1/4	23 kg
K 5/2 - D1"1/2-S	300	236	365	175	168	840	1280	327	171	144	10	18	260	380	430	564	Rp 1 1/2	25 kg
K 5/2 - D2"-S	300	236	365	175	168	840	1280	327	171	144	10	18	260	380	430	564	Rp 2	25 kg
K 6/2 - D2"-S	320	238	393	210	193	980	1560	438	213	183	40	23	283	380	556	588	Rp 2	25 kg
K 7/2 - D2"-S	320	238	393	210	193	980	1560	438	213	183	40	23	283	380	556	588	Rp 2	25 kg

F2*: Encumbrance with burner move back.

TC-TL*: see chapter "FLAME TUBE LENGTH"

BOILER PLATE

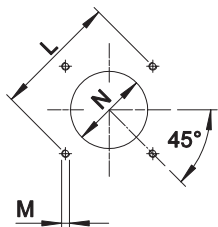

Fig. 4 Boiler plate

* Suggested dimension of connection between burner and generator.

MODEL		L min	L max	M	N min	N *	N max
K 5/2	mm	310	368	M12	185	185	250
K 6/2	mm	340	368	M14	220	220	250
K 7/2	mm	340	368	M14	220	220	250

FLAME TUBE LENGTH

Flame tube length must be selected based on the specifications supplied by boiler manufacturer and, in any case, it must be greater than the thickness of the boiler door included its insulation.

In case of boilers with flame inversion or front flue combustion chambers, it is necessary to insulate the area between the flame tube and front door with refractory material. This protection material must not impede flame tube extraction.

MODEL		TC	TL *
K 5/2	mm	250	315
K 6/2	mm	280 **	400
K 7/2	mm	280 **	400

** With spacer.

* For different flame lengths, please contact our Technical-Sales Department.

PRODUCT SPECIFICATION**SHORT DESCRIPTION**

Dual fuel gas/light-oil burners at two stages.

DETAILED SPECIFICATION

Dual fuel gas/light-oil burners at two stages, composed by:

- Aluminium frame;
- Fan at high pressurisation;
- Combustion head with adjustment at high performance and elevated flame stability equipped with blast tube and flame disc;
- Flange and insulating gasket for fixing at boiler;
- Three-phase power supply;
- Manual switch for the fuel selection gas/light-oil;
- Safety air pressure switch to stop the burner in lock-out in case of failed or anomalous fan operation;
- Equipped with gas train with one-block valve class A (1st stage + 2nd stage slow opening + safety);
- Gas valve proving system VPS as standard for model K 7/2, optional for models K 5/2 - K 6/2;
- Motor dedicated for the light-oil pump; it turns on simultaneously to the ignition transformer activation;
- Maximum gas pressure switch as standard for models K 6/2 - K 7/2, optional for model K 5/2;
- UV probe for flame detection;
- Supports and tierods for burner extraction;
- Easy extraction of combustion head without get off the burners by bolier;
- Servomotor for air shutter and for the consent of the 2nd stage operation;
- Moving shutter with total closure when idle in order to reduce at the least energy losses related to boiler cooling down;
- IP 40 electric protection level.

CONFORMING TO:

- CE rules;
- 2014/30/UE Directive E.M.C.;
- 2014/35/UE Directive LVD;
- 2006/42/CE - 2006/42/EG - 2006/42/EC Directive MD;
- Directive PED (art.4, par.3) 2014/68/EU;
- Reference rules: EN676 (gas) - EN267 (liquid fuel) - EN746-2 (industrial thermoprocessing equipment).

STANDARD EQUIPMENT

- Flexible pipes;
- Line filter;
- Isomart gasket;
- Nozzles;
- Flange with insulating gasket;
- Burner nameplate;
- Warranty;
- Instruction handbook for installation, use and maintenance.

OPTIONAL

- Noise protection;
- Antivibration couplings;
- Handle gas taps.