

K 750-1000-1300-1500-1800/M-EL



Dual fuel burners for gas and light oil at 2 stages progressive (hi-low flame) or PID fully modulating if equipped with modulation kit and probe.

Equipped with Lamtec BT340 electronic control box.

Fan at high pressurization, high efficiency combustion head with adjustment and high flame stability. Available versions for natural gas or LPG (to be specified at the order).

Gas train includes working valve, safety valve, minimum gas pressure switch, gas pressure filter-stabilizer and is supplied already assembled, connected and tested.

The adoption of strong metal components makes the burner durable also in heavy duty conditions.

Burners are supplied with nozzle, fuel switch, gasket for installation on boiler, flexible hoses, line filter.

The burners are equipped with an operating display that allows:

- Adjustment of the parameters of the burner operation
- Adjustment of the setpoint and operation range of the pressure / temperature probe
- Adjustment of the burner's curveset

With the addition of optional accessories (probes) thanks to the most advanced systems for automatic modulation in mechanical or electronic version, the burner constantly ensures the proper gas / air ratio. The maximum efficiency of the returns in each combustion point derived from the punctual adaptation of the thermal load to the heat requirements of the burner at any instant of operation.

In the version with the electronic cam the fuel / combustion air curve, more extended, is fully exploited, guaranteeing excellent performance in terms of accuracy and speed, even during the

calibration phase. A microprocessor monitors the different stages of the process and allows the correct repetition of the sequences of operation.

Some accessories are available, like: PC interface, VSD (inverter), O2 control, O2 + CO control, field bus (profibus, modbus, profinet).

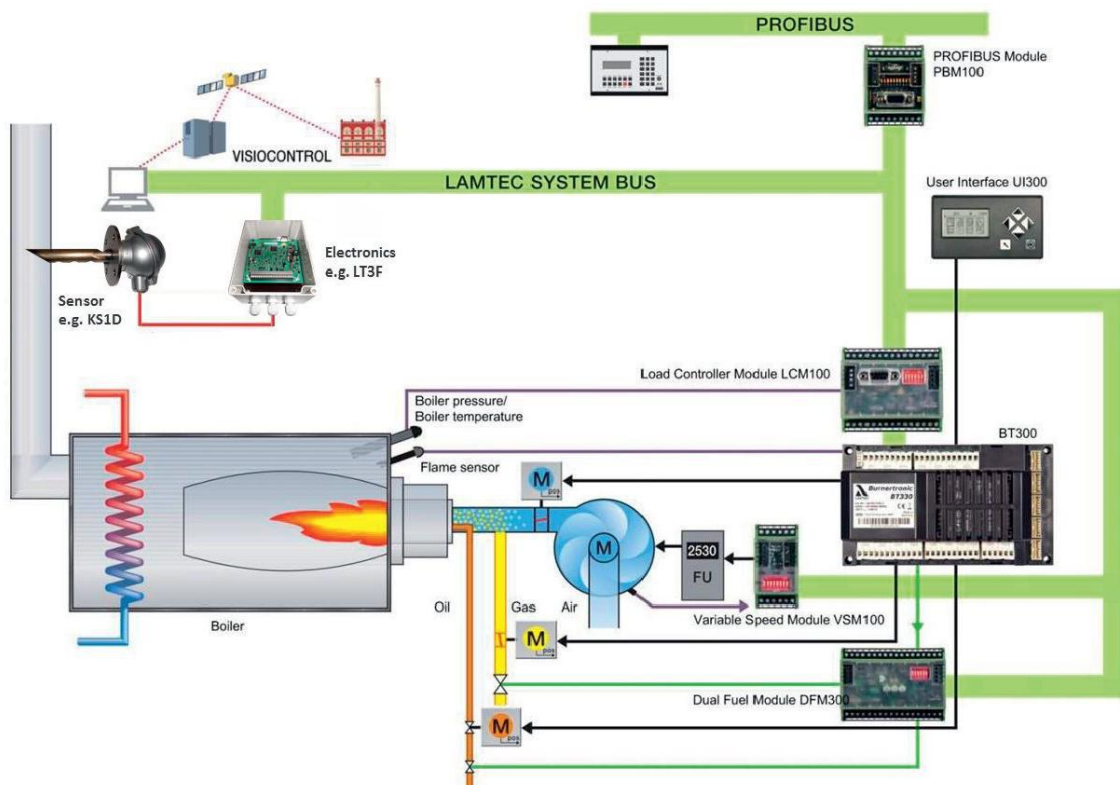

MODEL		K 750/M-EL	K 1000/M-EL	K 1300/M-EL
Thermal power min 1°st./min 2°st.-max 2°st. *	[Mcal/h]	1200/3400-7500	1200/3400-10000	1700/3600-11500
Thermal power min 1°st./min 2°st.-max 2°st. *	[kW]	1395/3953-8721	1395/3953-11628	1977/4186-13372
Gas flow G20 (natural gas) min 1°st./min 2°st.-max 2°st. *	[Nm³/h]	140/398-877	140/398-1170	199/421-1345
Gas flow G31 (L.P.G.) min 1°st./min 2°st.-max 2°st. *	[Nm³/h]	54/153-338	54/153-450	77/162-518
Fuel		Natural gas (second family) - L.P.G. (third family)		
Fuel category		I2R,I2H,I2L,I2E,I2E+,I2Er,I2ELL,I2E(R) / I3B/P,I3+,I3P,I3B,I3R		
Intermittent working operation (min, 1 stop every 24 hours) two stages progressive or modulating				
Enviromental conditions operation/storage		-15...+40°C / -20...+70°C ,relative humidity max. 80%		
Max temperature combustion air	[°C]	60	60	60
Minimum pressure gas train (DN65-S-F65 natural gas/L.P.G.) **	[mbar]	280/107	-/-	-/-
Minimum pressure gas train (DN80-S-F80 natural gas/L.P.G.) **	[mbar]	164/63	292/112	366/141
Minimum pressure gas train (DN100-S-F100 natural gas/L.P.G.) **	[mbar]	110/40	184/71	248/95
Minimum pressure gas train (DN125-S-F125 natural gas/L.P.G.) **	[mbar]	81/31	145/56	180/70
Maximum pressure at the entry of the valves (Pe.max)	[mbar]	500	500	500
LIGHT-OIL flow min 1°st./min 2°st.-max 2°st. *	[kg/h]	118/333-735	118/333-980	167/353-1127
Fuel		Light-oil 1.5°E at 20°C = 6.2cSt = 35sec Redwood N°1		
Nominal electric power	[kW]	25.5	34.5	41.5
Fan motor	[kW]	22	30	37
Pump motor	[kW]	3	4	4
Power supply		3~400V-1/N~230V-50Hz	3~400V-1/N~230V-50Hz	3~400V-1/N~230V-50Hz
Degree of electric protection		IP40	IP40	IP40
Noisiness***	[dB(A)]	89	91	93

* Reference conditions: Environment temperature 20°C - Barometric pressure 1013 mbars - Altitude 0 metre (sea level).

** Minimal feeding-gas pressure to the gas train to get the maximum power of the burner, considering counter-pressure in combustion chamber of value 0 (zero).

*** Measured sonorous pressure in the laboratory combustion, with functional burner on beta boiler to 1 metre of distance (UNI EN ISO 3746 law).

**FBR****TECHNICAL DATA****DUAL FUEL BURNERS_GAS/LIGHT OIL _ SERIE K**

SK073526_B_en

MODEL		K 1500/M-EL	K 1800/M-EL
Thermal power min 1°st./min 2°st.-max 2°st. *	[Mcal/h]	1700/3600-13000	2000/5000-15000
Thermal power min 1°st./min 2°st.-max 2°st. *	[kW]	1977/4186-15116	2325/5815-17442
Gas flow G20 (natural gas) min 1°st./min 2°st.-max 2°st. *	[Nm³/h]	199/421-1520	234/585-1754
Gas flow G31 (L.P.G.) min 1°st./min 2°st.-max 2°st. *	[Nm³/h]	77/162-585	90/225-676
Fuel		Natural gas (second family) - L.P.G. (third family)	
Fuel category		I2R,I2H,I2L,I2E,I2E+,I2Er,I2ELL,I2E(R) / I3B/P,I3+,I3P,I3B,I3R	
Intermittent working operation (min, 1 stop every 24 hours) two stages progressive or modulating			
Enviromental conditions operation/storage		-15...+40°C / -20...+70°C ,relative humidity max. 80%	
Max temperature combustion air	[°C]	60	60
Minimum pressure gas train (DN80-S-F80 natual gas/L.P.G.) **	[mbar]	-/142	-/-
Minimum pressure gas train (DN100-S-F100 natual gas/L.P.G.) **	[mbar]	220/88	370/-
Minimum pressure gas train (DN125-S-F125 natual gas/L.P.G.) **	[mbar]	191/70	307/-
Maximum pressure at the entry of the valves (Pe.max)	[mbar]	500	500
LIGHT-OIL flow min 1°st./min 2°st.-max 2°st. *	[kg/h]	167/353-1274	196/490-1470
Fuel		Light-oil 1.5°E at 20°C = 6.2cSt = 35sec Redwood N°1	
Nominal electric power	[kW]	49.5	60
Fan motor	[kW]	45	55
Pump motor	[kW]	4	5.5
Power supply		3~400V-1/N~230V-50Hz	3~400V-1/N~230V-50Hz
Degree of electric protection		IP40	IP40
Noiseness***	[dB(A)]	97	101

* Reference conditions: Environment temperature 20°C - Barometric pressure 1013 mbars - Altitude 0 metre (sea level).

** Minimal feeding-gas pressure to the gas train to get the maximum power of the burner, considering counter-pressure in combustion chamber of value 0 (zero).

*** Measured sonorous pressure in the laboratory combustion, with functional burner on beta boiler to 1 metre of distance (UNI EN ISO 3746 law).

FIRING RATES

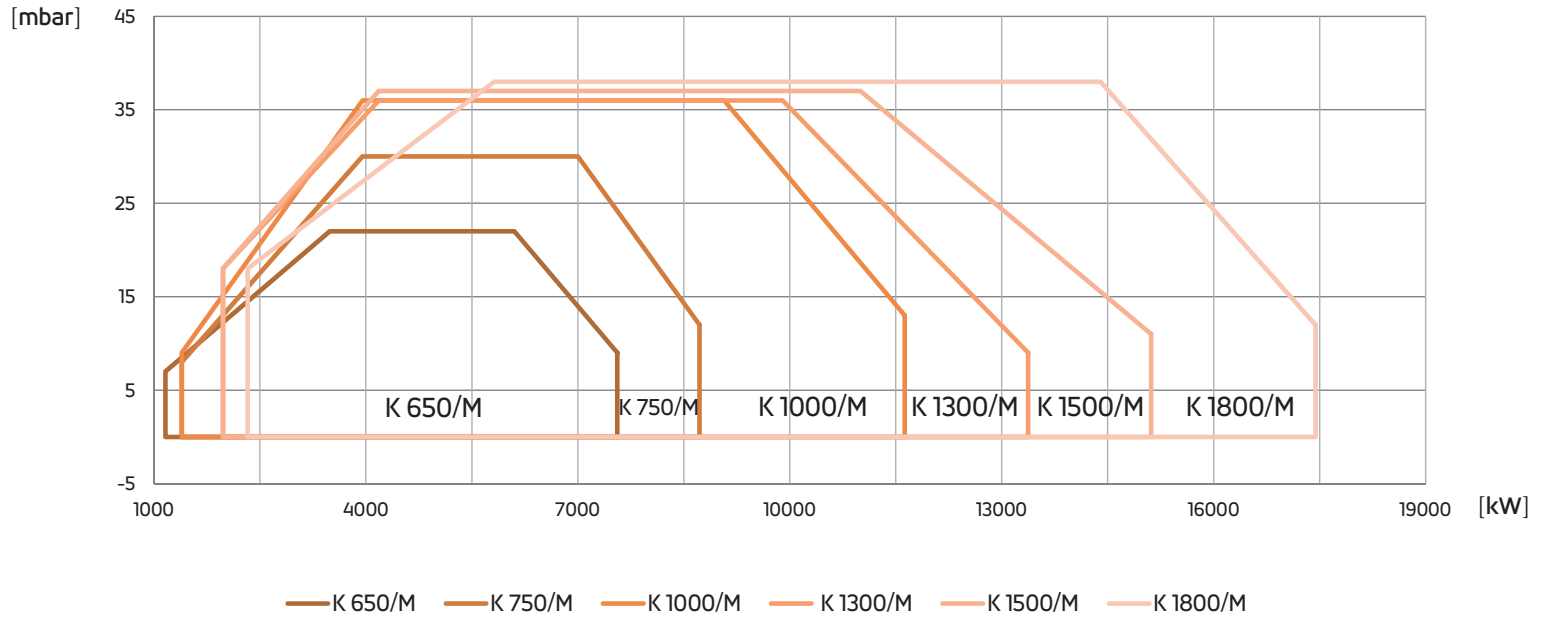

Fig. 1 X = Thermal power (kW) Y = Pression in the combustion chamber (mbar)

The firing rates has been obtained based on test boilers in accordance with EN267 standards and are indicative of matching the burner to the boiler. For the correct operation of the burner, combustion chamber dimensions must be in accordance with current regulation. In case of non-compliance, contact the manufacturer.



FBR

DIMENSIONS [mm]

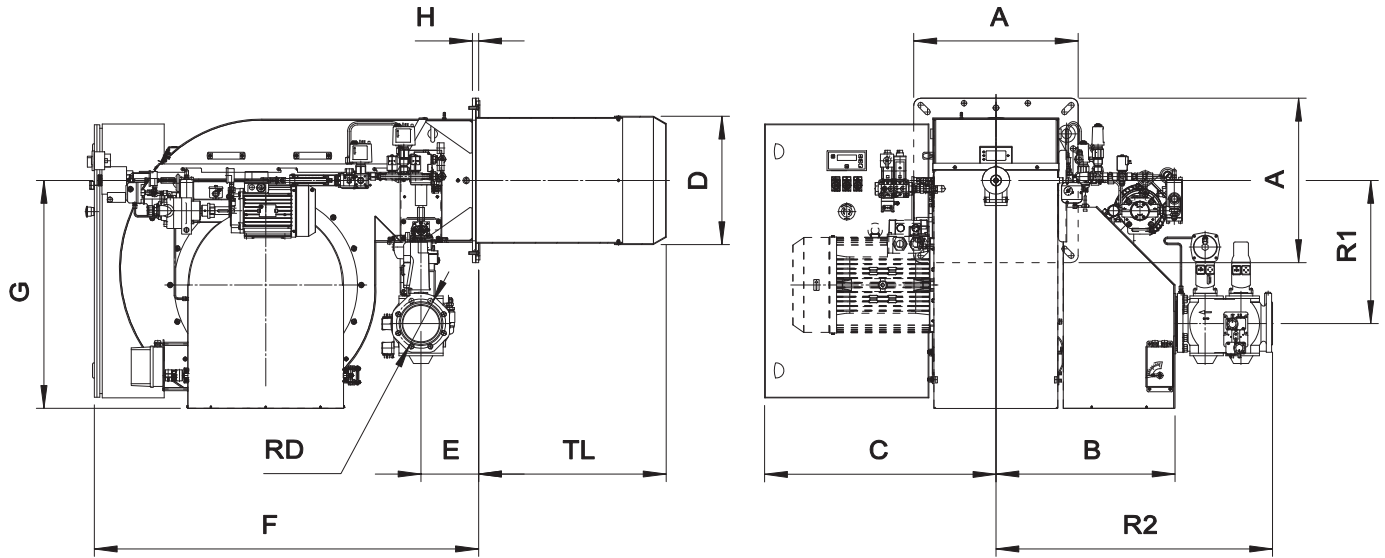

MODEL	A	B	C	D	E	F	G	H	R1	R2	RD	TL
K 750/M-EL	600	654	845	448	210	1403	832	22	523	970-1060	DN...	685
K 1000/M-EL	600	654	845	468	210	1403	832	22	523	970-1060	DN...	685
K 1300/M-EL	600	634	845	499	210	1403	832	22	523	970-1060	DN...	655
K 1500/M-EL	600	634	845	499	210	1403	832	22	523	970-1060	DN...	655
K 1800/M-EL	700	680	875	540	222	1555	884	22	476	1008-1098	DN...	685

BOILER PLATE

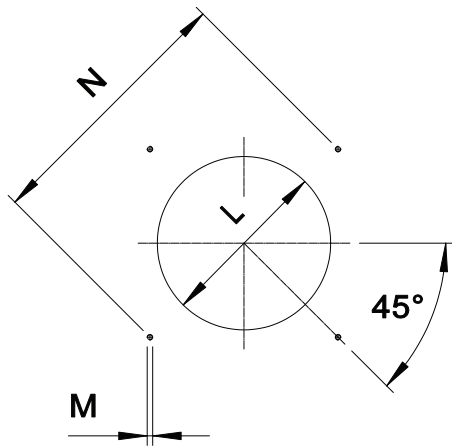

The dimensions of the boiler plate must be as indicated in the drawing.

MODEL	M	N min	N*	N Max	Lmin	Lmax
K 750/M-EL	mm M16	707	778	778	460	540
K 1000/M-EL	mm M16	707	778	778	480	540
K 1300/M-EL	mm M16	707	778	778	510	540
K 1500/M-EL	mm M16	707	778	778	510	540
K 1800/M-EL	mm M18	806	890	890	550	630

* Suggested dimension

PRODUCT SPECIFICATION**SHORT DESCRIPTION**

Dual fuel burners for gas and light-oil two stages progressive (hi-low flame) or modulating (PID fully modulating) if equipped with addition of optional modulation kit and probe.

DETAILED SPECIFICATION

Gas and Light-oil burner two stages progressive (hi-low flame) or modulating (PID fully modulating) if equipped with addition of optional modulation kit and probe; composed by:

- Burner frame made of steel completed by specific boiler plate;
- Centrifugal fan at high pressurization with reverse curved blades at low noisiness;
- Combustion head with adjustment at high performance and elevated flame stability equipped with steel blast tube and steel flame disc;
- Easy extraction of combustion head without get off the burners by boiler;
- Combustible-air adjustment for optimal combustion value;
- Flange and insulating gasket for fixing at boiler;
- Electronic control system for controlling and command the burner;
- UV Photocell for flame detection;
- Gas/light oil selector;
- Three-phase power supply;
- IP40 electric protection level;
- Safety air pressure switch to stop the burner in case of failed or anomalous fan operation;
- Spherical gas servocontrolled valve: progressive start and free way passage with total opening;
- Servomotor for air shutter, for the spherical gas valve and for the light-oil pressure regulator;
- Mobile shutter with total closure when idle for minimize the energetic losses related at boiler cooling;
- Gas train with A class safety valve and A class adjustment valve;
- Leakage control integrate in Lamtec BT340 system;
- Light-oil pressure regulator servo-controlled;
- Light oil gear pump operated by specific electric motor;
- Maximum gas pressure switch to stop the burner in lock-out in case of the gas pressure is higher then the set point value;
- Maximum light-oil pressure switch to stop the burner in case of the light-oil pressure on the return is higher then the set point;
- Pilot ignition (only for GAS fuel);
- Set up for the additional specific kit that transforms burner operation as modulating i.e.the modulating kit allows to supply any power between the minimum and maximum value based on instantaneous loading request.

CONFORMING TO:

- CE rules;
- 2014/30/UE Directive E.M.C.;
- 2014/35/UE Directive L.V.;
- 2006/42/CE - 2006/42/EG - 2006/42/EC Directive M.D.;
- Reference rules: EN676 (gas) - EN267 (liquid fuel) - EN746-2 (industrial thermoprocessing equipment)

STANDARD EQUIPMENT

- Flexible pipes for connection
- Line filter
- Isomart gasket
- Nozzle
- Flange with insulating gasket
- Burner nameplate
- Warranty
- Instruction handbook for installation, use and maintenance

OPTIONAL

- Power modulating kits for temperatures;
- Power modulating kits for pressures;
- Kit for input 4-20mA / 0-10Vdc;
- Temperature probe 0°C-400°C (PT 100 a 0° C);
- Temperature probe 0°C-350°C (J probe);
- Temperature probe 0°C-1200°C (K probe);
- Pressure probe 0-3 bar, 0-6 bar, 0-16 bar, 0-20 bar, 0-30 bar;
- Sensors and system for O₂ control (is suggest to add the VSD);
- Sensors and system for CO control (is suggest to add the VSD);
- Sensors and system for O₂-CO control (is suggest to add the VSD);
- Modules for field BUS (modbus - profibus - profinet);
- Noise protection;
- Antivibration couplings;
- Handle gas taps.