

GAS P70/MCE - GAS P100/MCE - GAS P150/MCE-03 - GAS P150/MCE

Burners for gas two stages progressive (hi-low flame) or modulating (PID fully modulating) if equipped with addition of optional modulation kit and probe.

They are composed by: die-cast aluminum body, fan at high pressurisation and combustion head with adjustment at high efficiency and high flame stability.

Compact overall dimensions and disposition rationalized of the components with accessibility facilitated for the operations of setting and maintenance.

Available in the versions METHANE (natural gas) or L.P.G. (to specify at the order) on demand specific versions for town gas, coal gas or biogas.

Gas train completely assembled and tested; complete of working valve with flow adjustment, safety valve, minimum gas pressure switch and gas filter.

Complete of flange and gasket for installation on generator.



Fig. 1 GAS P100/MCE

TECHNICAL DATA GAS P70/MCE - GAS P100/MCE

MODEL		GAS P70/MCE	GAS P100/MCE
Thermal power min. 1°st. / min. 2°st. - max. 2°st. *	[Mcal/h]	116/350-650	172/500-1000
Thermal power min. 1°st. / min. 2°st. - max. 2°st. *	[kW]	135/407-756	200/581-1163
Gas flow G20 (NATURAL GAS) min. 1°st. / min. 2°st. - max. 2°st. *	[Nm³/h]	13.5/41-76	20/58.4-117
Gas flow G31 (L.P.G.) min. 1°st. / min. 2°st. - max. 2°st. *	[Nm³/h]	5.2/15.7-29.3	7.8/22.6-45.2
Fuel: NATURAL GAS (second family) - L.P.G. (third family)			
Fuel category:		I2R,I2H,I2L,I2E,I2E+,I2Er,I2ELL, I2E(R) I3B/P,I3+,I3P,I3B,I3R	
Intermitted working operation (min. 1 stop every 24 hours) two stages progressive or modulating			
Environmental conditions operation / storage:		-15...+40°C / -20...+70°C, rel. humidity max. 80%	
Max. temperature combustion air	[°C]	60	60
Min. pressure gas train D1"1/4-S NATURAL GAS/L.P.G. **	[mbar]	33/34	85/52
Min. pressure gas train D1"1/2-S NATURAL GAS/L.P.G. **	[mbar]	25/24	37/29
Min. pressure gas train D2"-S NATURAL GAS/L.P.G. **	[mbar]	16/21,5	32/25
Min. pressure gas train DN65-FS65 NATURAL GAS/L.P.G. **	[mbar]	13/23.5	22/28
Min. pressure gas train DN80-FS80 NATURAL GAS/L.P.G. **	[mbar]	-	17/27.5
Max. pressure at the entry of valves (Pe. max)	[mbar]	360	360
Nominal electric power	[kW]	1.4	2.7
Fan motor	[kW]	1.1	2.2
Nominal motor current absorption	[A]	2.7	5.4
Nominal auxiliary absorption	[A]	0.6	0.6
Power supply:		3~400V,1N~230V - 50Hz	
Electric protection degree:		IP 40	IP 40
Noisiness *** min. - max.	[dB(A)]	72-78	81-82
Burner weight ****	[kg]	51	73

* Reference conditions: Environment temperature 20°C - Barometric pressure 1013 mbars - Altitude 0 metre (sea level).

** Minimal feeding-gas pressure to the gas train to get the maximum power of the burner, considering counter-pressure in combustion chamber of value 0 (zero).

*** Measured sonorous pressure in the laboratory combustion, with functional burner on beta boiler to 1 metre of distance (UNI EN ISO 3746 law - method of control Class 3 - The tolerance of the measured pressure can be taken equal to ± 1 [dB(A)]).

**** For burner with long head add 3 kg to the weight.

TECHNICAL DATA GAS P150/MCE-03 - GAS P150/MCE

MODEL		GAS P150/MCE-03	GAS P150/MCE
Thermal power min. 1°st. / min. 2°st. - max. 2°st. *	[Mcal/h]	200/700-1300	240/700-1500
Thermal power min. 1°st. / min. 2°st. - max. 2°st. *	[kW]	232/814-1511	279/814-1744
Gas flow G20 (NATURAL GAS) min. 1°st. / min. 2°st. - max. 2°st. *	[Nm³/h]	23.3/81.7-151.9	28/81.7-175.2
Gas flow G31 (L.P.G.) min. 1°st. / min. 2°st. - max. 2°st. *	[Nm³/h]	9/31.6-58.8	10.8/31.6-67.8
Fuel: NATURAL GAS (second family) - L.P.G. (third family)			
Fuel category:	I2R,I2H,I2L,I2E,I2E+,I2Er,I2ELL, I2E(R) I3B/P,I3+,I3P,I3B,I3R		
Intermitted working operation (min. 1 stop every 24 hours) two stages progressive or modulating			
Environmental conditions operation / storage:	-15...+40°C / -20...+70°C, rel. humidity max. 80%		
Max. temperature combustion air	[°C]	60	60
Min. pressure gas train D2"-S NATURAL GAS/L.P.G. **	[mbar]	52/43.2	54,5/35
Min. pressure gas train DN65-FS65 NATURAL GAS/L.P.G. **	[mbar]	33/38	36/33
Min. pressure gas train DN80-FS80 NATURAL GAS/L.P.G. **	[mbar]	23/35	27/31
Max. pressure at the entry of valves (Pe. max)	[mbar]	360	360
Nominal electric power	[kW]	3.4	3.4
Fan motor	[kW]	3	3
Nominal motor current absorption	[A]	6	6
Nominal auxiliary absorption	[A]	0.6	0.6
Power supply:	3~400V,1N~230V - 50Hz		
Electric protection degree:		IP 40	IP 40
Noisiness *** min. - max.	[dB(A)]	83-84	83-84
Burner weight ****	[kg]	96	94

* Reference conditions: Environment temperature 20°C - Barometric pressure 1013 mbars - Altitude 0 metre (sea level).

** Minimal feeding-gas pressure to the gas train to get the maximum power of the burner, considering counter-pressure in combustion chamber of value 0 (zero).

*** Measured sonorous pressure in the laboratory combustion, with functional burner on beta boiler to 1 metre of distance (UNI EN ISO 3746 law - method of control Class 3 - The tolerance of the measured pressure can be taken equal to ± 1 [dB(A)]).

**** For burner with long head add 3 kg to the weight.

OPERATING RANGE DIAGRAMS

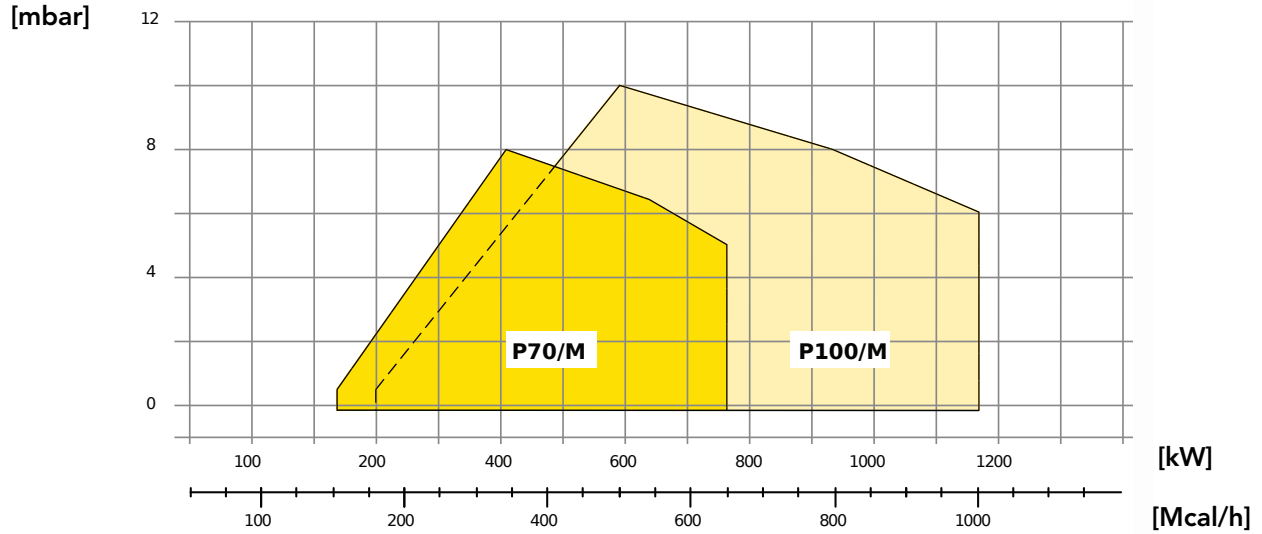

Fig. 2 X = Thermal power Y = Pression in the combustion chamber

The firing rates has been obtained based on test boilers in accordance with EN267 standards and are indicative of matching the burner to the boiler. For the correct operation of the burner, combustion chamber dimensions must be in accordance with current regulation. In case of non-compliance, contact the manufacturer.

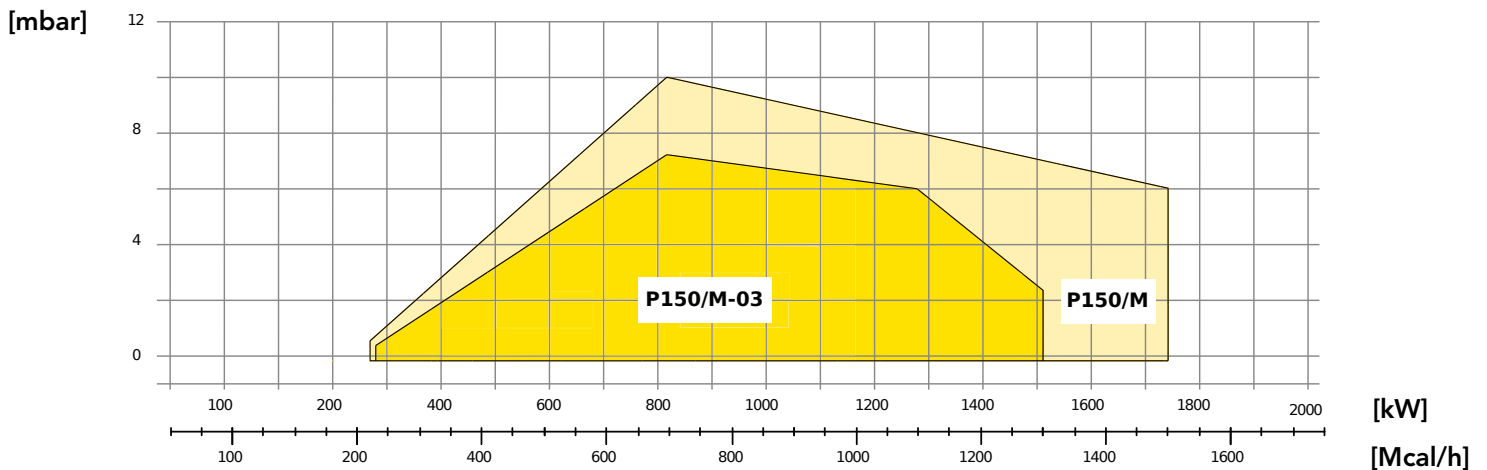

Fig. 3 X = Thermal power Y = Pression in the combustion chamber

The firing rates has been obtained based on test boilers in accordance with EN267 standards and are indicative of matching the burner to the boiler. For the correct operation of the burner, combustion chamber dimensions must be in accordance with current regulation. In case of non-compliance, contact the manufacturer.

DIMENSIONS [MM]

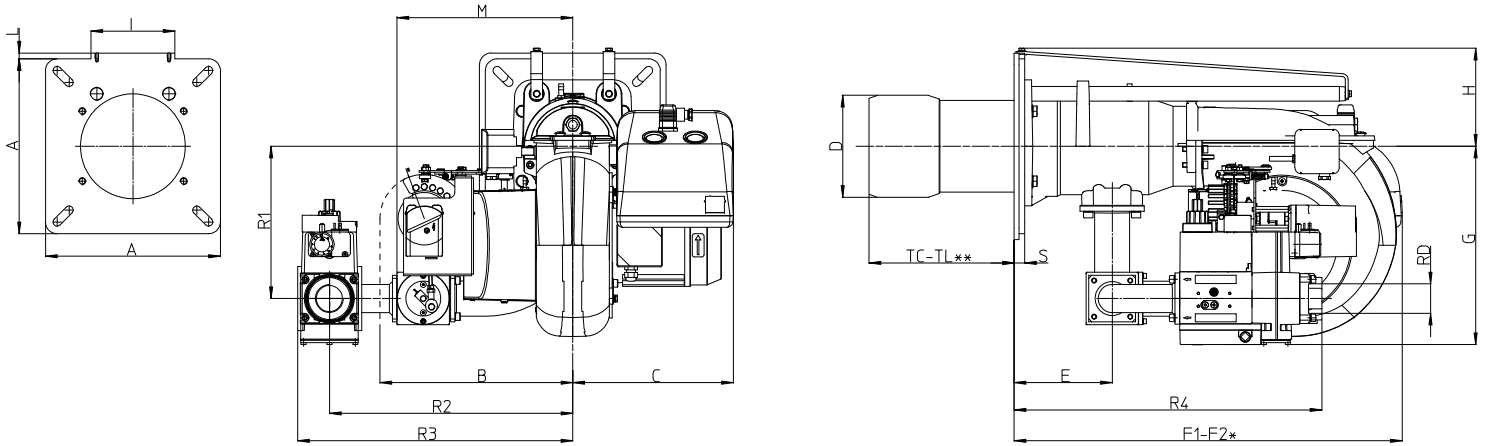

Fig. 4 Dimensions GAS P70/MCE - GAS P100/MCE

MODEL	A	B	C	D	E	F1	F2	G	H	I	L	M	S	R1	R2	R3	R4	Gas train weight
GAS P70/MCE - D1"1/4-S	300	331	275	175	168	670	1100	327	168	144	10	302	18	261	420	473	510	6 kg
GAS P70/MCE - D1"1/2-S	300	331	275	175	168	670	1100	340	168	144	10	302	18	261	418	473	528	8 kg
GAS P70/MCE - D2"-S	300	331	275	175	168	670	1100	340	168	144	10	302	18	261	418	473	528	11 kg
GAS P70/MCE - DN65-FS65	300	331	275	175	168	670	1170	349	168	144	10	302	18	261	457	550	561	31 kg
GAS P100/MCE - D1"1/4-S	300	382	350	185	184	670	1170	438	171	0	0	346	18	261	462	520	462	6 kg
GAS P100/MCE - D1"1/2-S	300	382	350	185	184	670	1170	438	171	0	0	346	18	261	462	520	462	8 kg
GAS P100/MCE - D2"-S	300	382	350	185	184	660	1170	438	171	0	0	346	18	261	462	517	543	11 kg
GAS P100/MCE - DN65-FS65	300	382	350	185	184	810	1390	438	171	0	0	346	18	261	501	594	577	31 kg
GAS P100/MCE - DN80-FS80	300	382	350	185	184	810	1390	438	171	0	0	346	18	261	557	724	617	/

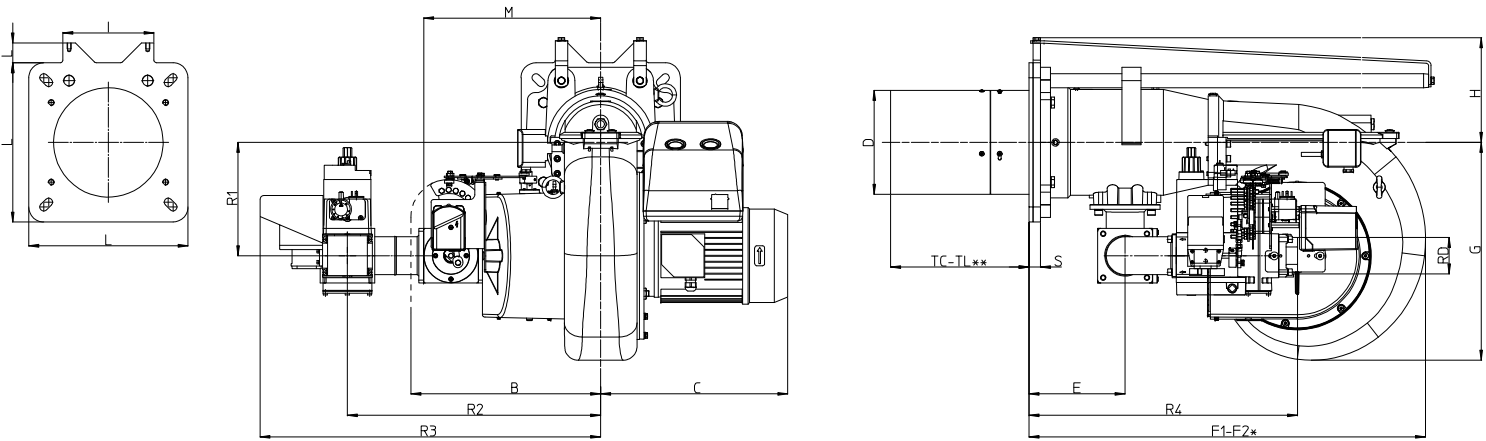
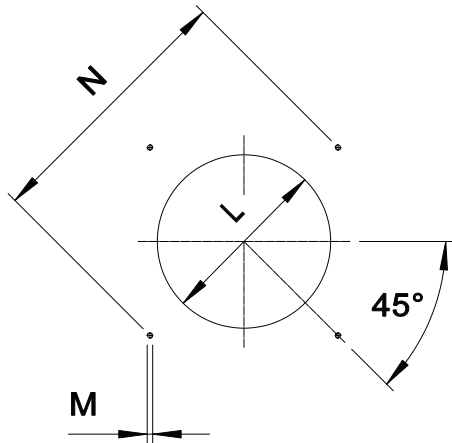

Fig. 5 Dimensions GAS P150/MCE-03 - GAS P150/MCE

MODELLO	A	B	C	D	E	F1	F2	G	H	I	L	M	S	R1	R2	R3	R4	Gas train weight
GAS P150/MCE-03 - D2"-S	320	382	376	209	193	810	1390	438	213	183	40	356	23	228	509	685	540	9 kg
GAS P150/MCE-03 - DN65-FS65	320	382	376	209	193	810	1390	438	213	183	40	356	23	228	509	685	586	37 kg
GAS P150/MCE-03 - DN80-FS80	320	382	376	209	193	810	1390	438	213	183	40	356	23	228	550	739	626	47 kg
GAS P150/MCE - D2"-S	320	382	376	209	193	810	1390	438	213	183	40	356	23	228	509	685	540	9 kg
GAS P150/MCE - DN65-FS65	320	382	376	209	193	810	1390	438	213	183	40	356	23	228	509	687	586	37 kg
GAS P150/MCE - DN80-FS80	320	382	376	209	193	810	1390	438	213	183	40	356	23	228	550	741	626	47 kg

*F2: Overall dimension with the burner out in position of maintenance.

**TC-TL: see "flame tube length"



* Suggested dimension of connection between burner and generator.

Fig. 6 Boiler plate

MODEL		L min	L *	L max	M	N min	N max
GAS P70/MCE	mm	185	185	250	M12	310	368
GAS P100/MCE	mm	195	195	250	M12	340	368
GAS P150/MCE-03	mm	220	220	250	M14	340	368
GAS P150/MCE	mm	220	220	250	M14	340	368

FLAME TUBE LENGTH

Flame tube length must be selected based on the specifications supplied by boiler manufacturer and, in any case, it must be greater than the thickness of the boiler door included its insulation.
 In case of boilers with flame inversion or front flue combustion chambers, it is necessary to insulate the area between the flame tube and front door with refractory material. This protection material must not impede flame tube extraction.

MODEL		TC	TL **
GAS P70/MCE	mm	250	385
GAS P100/MCE	mm	250	385
GAS P150/MCE-03	mm	280	400
GAS P150/MCE	mm	280	400

** For different flame lengths, please contact our Technical-Sales Department.

BURNER SIGNAL DESCRIPTION

In the picture below there are indicated all the signalation present on the burner:

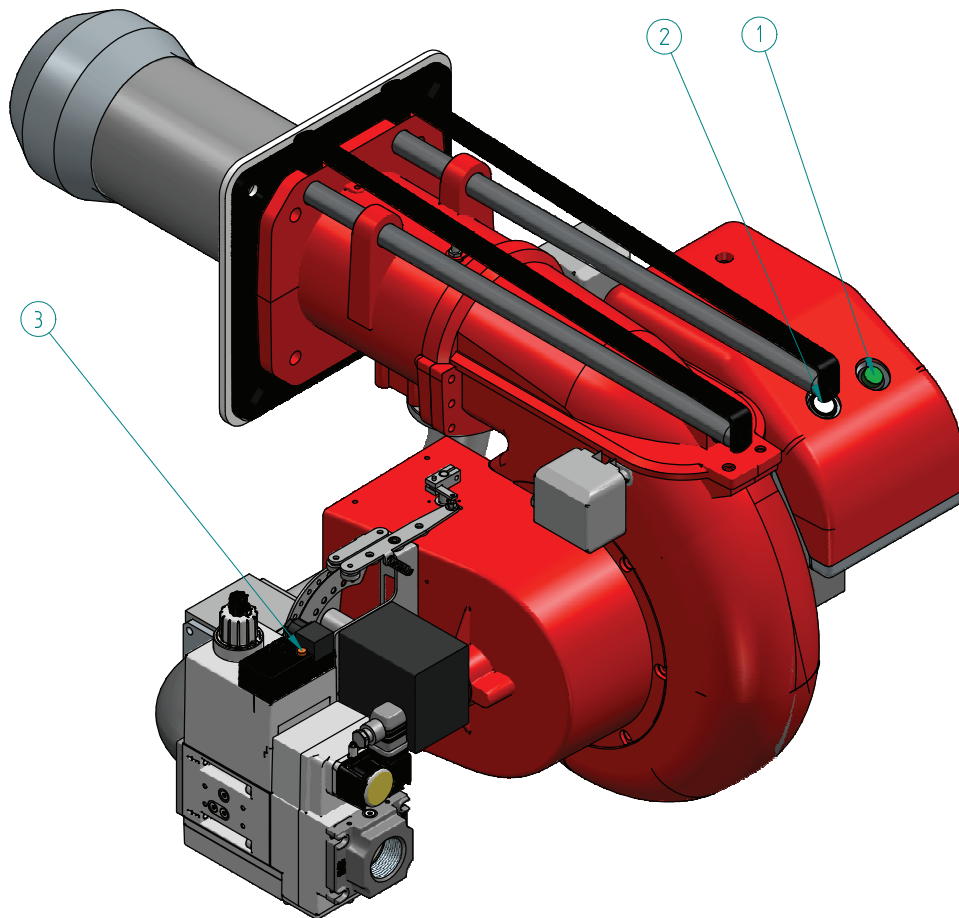



Fig. 7 Burner signal description

LEGEND

- 1) ON/OFF button
- 2) Reset from lockout button + status lamp
- 3) GAS valve lamp *

* In the gas train DN65-FS65 and DN80-FS80 there are 2 lamps.

 The multicolor signal lamp in the lockout reset button (pos.2) is the key indicating element for visual diagnostics and interface diagnostics.

In normal operation, the different operating states are indicated in the form of color codes; please refer to electrical device handbook supplied with the present instructions.

 After a non-alterable lockout, the red signal lamp in the lockout reset button (pos.2) lights up. By pressing the lockout reset button (pos.2) for more than 3 seconds, the visual diagnostics of the cause of fault can be activated; please refer to electrical device handbook supplied with the present instructions.

For close the diagnostics mode and for switch on the burner again, it is necessary to reset the burner control. Press the lockout reset button (pos.2) for about 1 second (<3 seconds).

 After a non-alterable lockout, the red signal lamp in the lockout reset button (pos.2) lights up. For reset the control box press the lockout reset button (pos.2) for about 1 second (<3 seconds).

PRODUCT SPECIFICATION**SHORT DESCRIPTION**

Burners for gas two stages progressive (hi-low flame) or modulating (PID fully modulating) if equipped with addition of optional modulation kit and probe.

DETAILED SPECIFICATION

Burner for gas two stages progressive (hi-low flame) or modulating (PID fully modulating) if equipped with addition of optional modulation kit and probe; composed by:

- Die-cast aluminum body;
- Fan at high pressurisation;
- Combustion head with adjustment at high performance and elevated flame stability equipped with inox steel blast tube and steel flame disc;
- Flange and insulating gasket for fixing at boiler;
- Three-phase power supply;
- Safety air pressure switch to stop the burner in lock-out in case of failed or anomalous fan operation;
- Gas train with safety valve class A, adjustment valve class A and valve proving system as standard for models: GAS P150/MCE-03 - GAS P150/MCE;
- Ionisation probe for flame detection;
- IP 40 electric protection level;
- Spherical gas valve servo-controlled; progressive start and free way passage with total opening;
- Servomotor for air shutter and for the spherical gas valve;
- Moving shutter with total closure when idle in order to reduce at the least energy losses related to boiler cooling down;
- Supports and tierods for burner extraction;
- Easy extraction of combustion head without get off the burners by boiler;
- Maximum gas pressure switch to stop the burner in lock-out in case of the gas pressure is higher then the set point value, as standard for models: GAS P100/MCE - GAS P150/MCE-03 - GAS P150/MCE;
- Set up for the additional specific kit that transforms burner operation as modulating i.e. the modulating kit allows to supply any power between the minimum and the maximum value based on instantaneous loading request.

CONFORMING TO:

- CE rules;
- 2014/30/UE Directive E.M.C.;
- 2014/35/UE Directive L.V.;
- 2006/42/CE - 2006/42/EG - 2006/42/EC Directive M.D.;
- For models GAS P70-100/MCE: 2016/426/UE Regulation;
- Reference rules: EN676 (gas) – EN 746-2 (industrial thermoprocessing equipment).

STANDARD EQUIPMENT

- Isomart gasket;
- Flange with insulating gasket;
- Burner nameplate;
- Warranty;
- Instruction handbook for installation, use and maintenance.

OPTIONAL

- Power modulating kits for temperatures;
- Power modulating kits for pressures;
- Temperature probe 0°C-400°C (PT 100 a 0° C);
- Temperature probe 0°C-1200°C (K probe);
- Pressure probe 0-3 bar, 0-6 bar. 0-16 bar, 0-20 bar, 0-30 bar;
- Noise protection;
- Antivibration couplings;
- Handle gas taps.