

## GAS XP60CE

Burners for gas at single stage.

They are composed by: fan at high pressurisation and combustion head with adjustment at high efficiency and high flame stability.

Compact overall dimensions and disposition rationalized of the components with accessibility facilitated for the operations of setting and maintenance.

Available in the versions METHANE (natural gas) or L.P.G. (to specify at the order) on demand specific versions for town gas, coal gas or biogas.

Gas train completely assembled and tested; complete of single-stage working valve with flow adjustment, safety valve, minimum gas pressure switch and gas filter.

Complete of flange and gasket for installation on generator.



Fig. 1 GAS XP60CE

## TECHNICAL DATA GAS XP60CE

MODEL	GAS XP60CE	
Thermal power min. - max. *	[Mcal/h]	200-450
Thermal power min. - max. *	[kW]	232-523
Gas flow G20 (NATURAL GAS) min. - max. *	[Nm <sup>3</sup> /h]	23.4-52.6
Gas flow G31 (L.P.G.) min. - max. *	[Nm <sup>3</sup> /h]	9-20.3
Fuel: NATURAL GAS (second family) - L.P.G. (third family)		
Fuel category:	I2R,I2H,I2L,I2E,I2E+,I2Er,I2ELL, I2E(R) I3B/P,I3+,I3P,I3B,I3R	
Intermittent working operation (min. 1 stop every 24 hours) single stage		
Environmental conditions operation / storage:	-15...+40°C / -20...+70°C, rel. humidity max. 80%	
Max. temperature combustion air	[°C]	60
Minimum pressure gas train D1"-S NATURAL GAS/L.P.G. **	[mbar]	47/30
Minimum pressure gas train D1"1/4-S NATURAL GAS/L.P.G. **	[mbar]	21/23
Minimum pressure gas train D1"1/2-S NATURAL GAS/L.P.G. **	[mbar]	16/-
Maximum pressure at the entry of valves (Pe. max)	[mbar]	360
Nominal electric power	[W]	935
Fan motor	[W]	740
Nominal power absorption	[A]	2
Nominal auxiliary absorption	[A]	0.5
Power supply:	3~400V, 1N~230V- 50Hz	
Electric protection degree:	IP 40	
Noisiness *** min. - max.	[dB(A)]	73-76
Burner weight ****	[kg]	31

\* Reference conditions: Environment temperature 20°C - Barometric pressure 1013 mbars - Altitude 0 metre (sea level).

\*\* Minimal feeding-gas pressure to the gas train to get the maximum power of the burner, considering counter-pressure in combustion chamber of value 0 (zero).

\*\*\* Measured sonorous pressure in the laboratory combustion, with functional burner on beta boiler to 1 metre of distance (UNI EN ISO 3746 law).

\*\*\*\* For burner with long head add 1 kg to the weight.

### OPERATING RANGE DIAGRAM

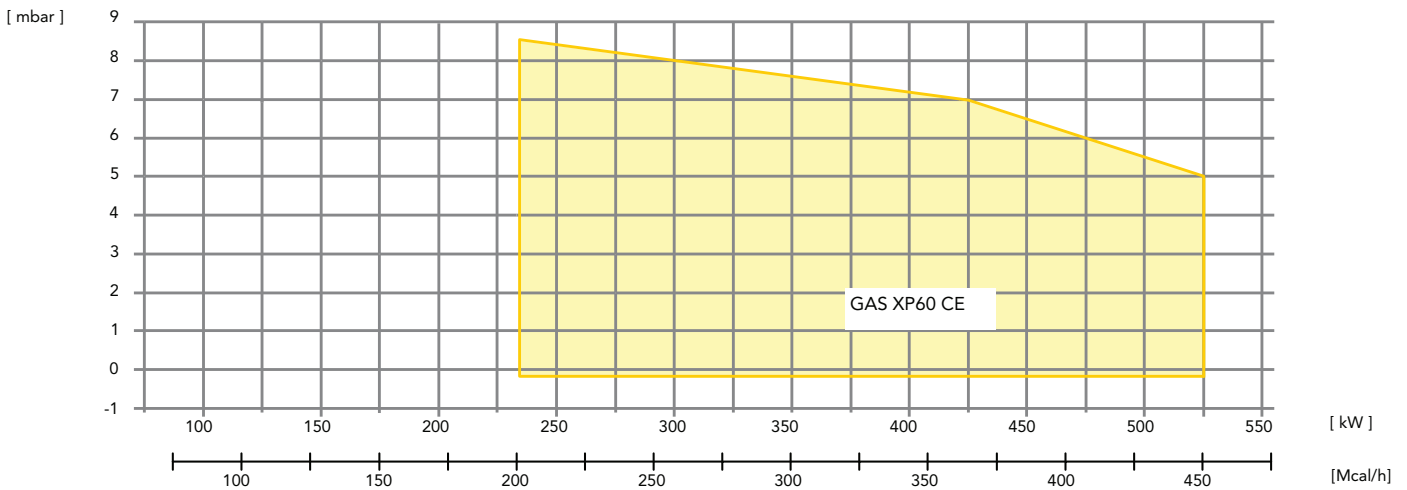

**Fig. 2** X = Thermal power Y = Pressure in the combustion chamber

The firing rates has been obtained based on test boilers in accordance with EN267 standards and are indicative of matching the burner to the boiler. For the correct operation of the burner, combustion chamber dimensions must be in accordance with current regulation. In case of non-compliance, contact the manufacturer.



FBR

DIMENSIONS [MM]

GAS BURNERS AT SINGLE STAGE

SK071035\_B\_en

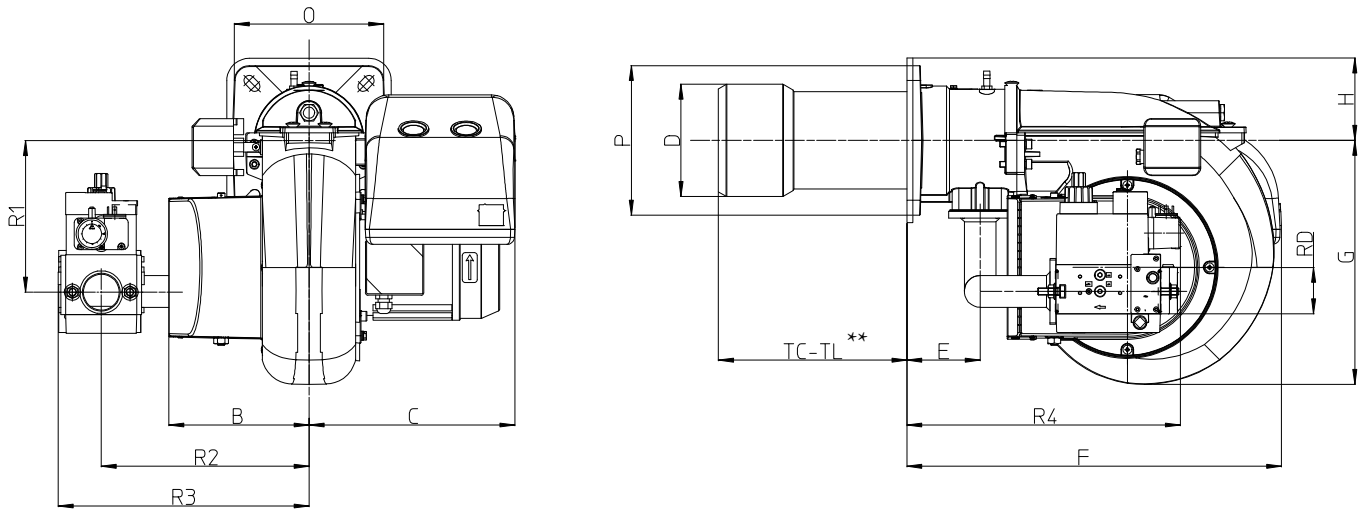
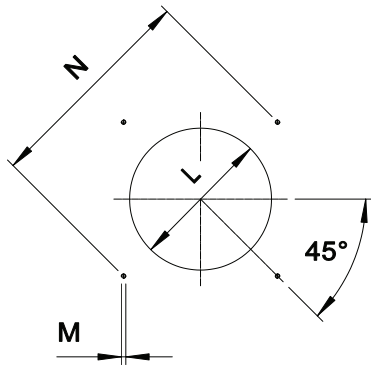

Fig. 3 Dimensions GAS XP60CE

MODEL	B	C	D	E	F	G	H	O	P	R1	R2	R3	R4	RD
GAS XP60CE - D1"-S	188	275	150	98	793	327	90	200	200	203	278	336	366	Rp 1
GAS XP60CE - D1"1/4-S	188	275	150	98	793	327	90	200	200	202	280	338	366	Rp 1 1/4
GAS XP60CE - D1"1/2-S	188	275	150	98	793	327	90	200	200	202	280	335	443	Rp 1 1/2

\*\*TC-TL: see "flame tube length"

BOILER PLATE



\* Suggested dimension of connection between burner and generator.

Fig. 4 Boiler plate

MODEL		L *	M	N min	N max
GAS XP60CE	mm	160	M10	205	226

FLAME TUBE LENGTH

Flame tube length must be selected based on the specifications supplied by boiler manufacturer and, in any case, it must be greater than the thickness of the boiler door included its insulation.

In case of boilers with flame inversion or front flue combustion chambers, it is necessary to insulate the area between the flame tube and front door with refractory material. This protection material must not impede flame tube extraction.

MODEL		TC	TL **
GAS XP60CE	mm	250	335

\*\* For different flame lengths, please contact our Technical-Sales Department.

**BURNER SIGNAL DESCRIPTION**

In the picture below there are indicated all the signalation present on the burner:

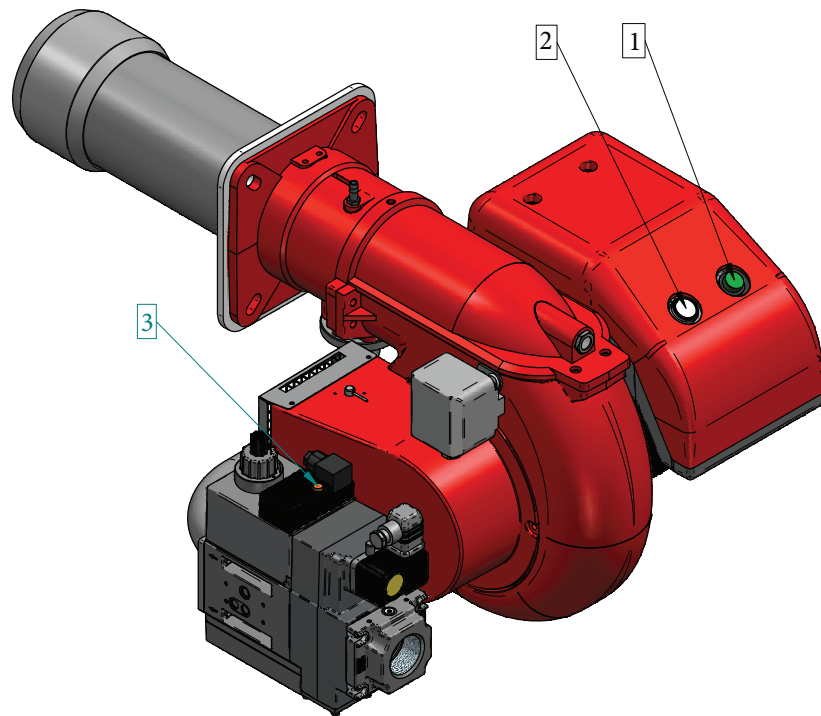

**Fig. 5** Burner signal description

**LEGEND**

- 1) ON/OFF button
- 2) Reset from lockout button + status lamp
- 3) GAS valve lamp

💡 The multicolor signal lamp in the lockout reset button (pos.2) is the key indicating element for visual diagnostics and interface diagnostics.

In normal operation, the different operating states are indicated in the form of color codes; please refer to electrical device handbook supplied with the present instructions.

💡 After a non-alterable lockout, the red signal lamp in the lockout reset button (pos.2) lights up. By pressing the lockout reset button (pos.2) for more than 3 seconds, the visual diagnostics of the cause of fault can be activated; please refer to electrical device handbook supplied with the present instructions.

For close the diagnostics mode and for switch on the burner again, it is necessary to reset the burner control. Press the lockout reset button (pos.2) for about 1 second (<3 seconds).

💡 After a non-alterable lockout, the red signal lamp in the lockout reset button (pos.2) lights up. For reset the control box press the lockout reset button (pos.2) for about 1 second (<3 seconds).

## PRODUCT SPECIFICATION

### SHORT DESCRIPTION

Burners for gas at single stage.

### DETAILED SPECIFICATION

Burner for gas at single stage; composed by:

- Fan at high pressurisation;
- Combustion head with adjustment at high performance and elevated flame stability equipped with inox steel blast tube and steel flame disc;
- Flange and insulating gasket for fixing at boiler;
- Three-phase power supply;
- Safety air pressure switch to stop the burner in lock-out in case of failed or anomalous fan operation;
- Gas train with safety valve class A, adjustment 1st stage valve class A;
- Ionisation probe for flame detection;
- IP 40 electric protection level;
- Easy extraction of combustion head without get off the burners by bolier.

### CONFORMING TO:

- CE rules;
- 2014/30/UE Directive E.M.C.;
- 2014/35/UE Directive L.V.;
- 2006/42/CE - 2006/42/EG - 2006/42/EC Directive M.D.;
- GAS 2016/426/UE Regulation;
- Reference rules: EN676 (gas) – EN 746-2 (industrial thermoprocessing equipment).

### STANDARD EQUIPMENT

- Isomart gasket;
- Flange with insulating gasket;
- Burner nameplate;
- Warranty;
- Instruction handbook for installation, use and maintenance.

### OPTIONAL

- Noise protection;
- Antivibration couplings;
- Handle gas taps.