

## K 190/M - K 250/M

Dual fuel burners gas/light oil two stages progressive (hi-low flame) or modulating (PID fully modulating) if equipped with addition of optional modulation kit and probe.

They are composed by: fan at high pressurisation and combustion head with adjustment at high efficiency and high flame stability.

Compact overall dimensions and disposition rationalized of the components with accessibility facilitated for the operations of setting and maintenance.

The adoption of strong metal components makes the burner durable also in heavy duty conditions.

GAS fuel available in the versions METHANE (natural gas) or L.P.G. (to specify at the order) on demand specific versions for town gas, coal gas or biogas.

Gas train completely assembled and tested; complete of working valve class A, safety valve class A, valve proving system, minimum gas pressure switch - filter stabilizer.

Burners are supplied with nozzle, fuel selection switch, flange, gasket for installation on boiler, flexible hoses, line filter.

Available also special versions with VSD (INVERTER) and ELECTRONIC CONTROL BOX.

## TECHNICAL DATA AND OPERATING RANGE DIAGRAM K 190/M - K 250/M

MODEL		K 190/M	K 250/M
Thermal power min. 1°st. / min. 2°st. - max. 2°st. *	[Mcal/h]	300/900-2060	400/1000-2500
Thermal power min. 1°st. / min. 2°st. - max. 2°st. *	[kW]	349/1046-2395	465/1163-2907
Gas flow G20 (NATURAL GAS) min. 1°st. / min. 2°st. - max. 2°st. *	[Nm³/h]	35/105-241	47/117-292
Gas flow G31 (L.P.G.) min. 1°st. / min. 2°st. - max. 2°st. *	[Nm³/h]	14/41-93	18/45-113
Fuel: NATURAL GAS (second family) - L.P.G. (third family)			
Fuel category:		I2R,I2H,I2L,I2E,I2E+,I2Er,I2ELL, I2E(R)B/I3B/P,I3+,I3P,I3B,I3R	
Intermittent working operation (min. 1 stop every 24 hours) two stage progressive or modulating			
Environmental conditions operation / storage:		-15...+40°C / -20...+70°C, rel. humidity max. 80%	
Max. temperature combustion air	[°C]	60	60
Minimum pressure gas train D2" FS50 NATURAL GAS/L.P.G. **	[mbar]	147/76	209/110
Minimum pressure gas train DN65 FS65 NATURAL GAS/L.P.G. **	[mbar]	80/47	114/66
Minimum pressure gas train DN80 FS80 NATURAL GAS/L.P.G. **	[mbar]	60/41	86/58
Minimum pressure gas train DN100 FS100 NATURAL GAS/L.P.G. **	[mbar]	54/35	77/50
Maximum pressure at the entry of valves (Pe. max)	[mbar]	360-500	360-500
LIGHT-OIL flow min. 1°st. / min. 2°st. - max. 2°st. *	[kg/h]	30/90-206	40/100-250
Fuel: light-oil 1.5°E at 20°C = 6.2 cSt = 35sec Redwood N°1			
Nominal electric power	[kW]	7	9
Fan motor	[kW]	5.5	7.5
Pump motor	[kW]	1.1	1.1
Nominal absorption powers	[A]	15	19
Nominal absorption auxiliary	[A]	0.5	0.5
Power supply:		3~400V, 1N~230V - 50Hz	
Electric protection degree:		IP40	IP40
Noisiness *** min. - max.	[dB(A)]	81-82	82-86
Burner weight	[kg]	140	152

\* Reference conditions: Environment temperature 20°C - Barometric pressure 1013 mbars - Altitude 0 metre (sea level).

\*\* Minimal feeding-gas pressure to the gas train to get the maximum power of the burner, considering counter-pressure in combustion chamber of value 0 (zero).

\*\*\* Measured sonorous pressure in the laboratory combustion, with functional burner on beta boiler to 1 metre of distance (UNI EN ISO 3746 law).

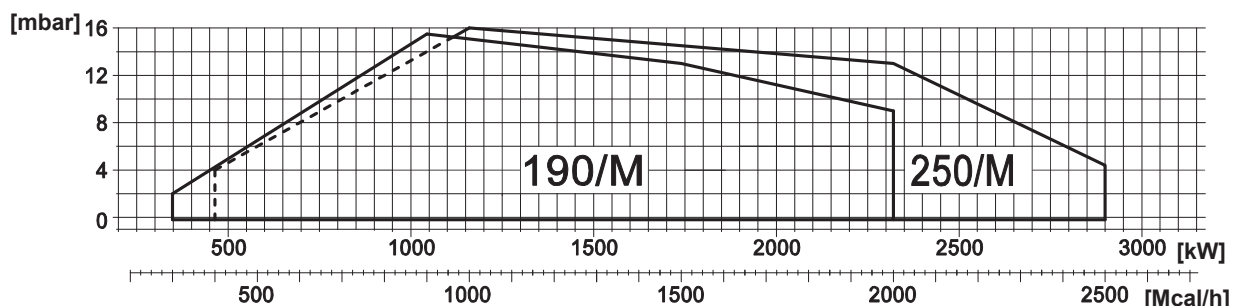

Fig. 2 X = Thermal power Y = pressure in combustion chamber

The firing rates has been obtained based on test boilers in accordance with EN267 standards and are indicative of matching the burner to the boiler. For the correct operation of the burner, combustion chamber dimensions must be in accordance with current regulation. In case of non-compliance, contact the manufacturer.

## DIMENSIONS [MM]

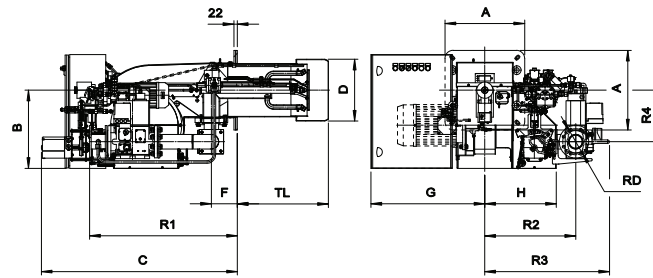

Fig. 3 Dimensions

MODEL	A	B	C	D	F	G	H	R1	R2	R3	R4	RD
K 190/M - D2"	370	460	1132	265	145	545	363	598	509	672	254	Rp 2
K 190/M - DN65	370	460	1132	265	145	545	363	688	480	694	254	DN65
K 190/M - DN80	370	460	1132	265	145	545	363	708	480	680	254	DN80
K 190/M - DN100	370	460	1132	265	145	545	363	748	480	700	254	DN100
K 250/M - D2"	370	460	1132	265	145	545	363	598	509	672	254	Rp 2
K 250/M - DN65	370	460	1132	265	145	545	363	688	480	694	254	DN65
K 250/M - DN80	370	460	1132	265	145	545	363	708	480	680	254	DN80
K 250/M - DN100	370	460	1132	265	145	545	363	748	480	700	254	DN100

## BOILER PLATE

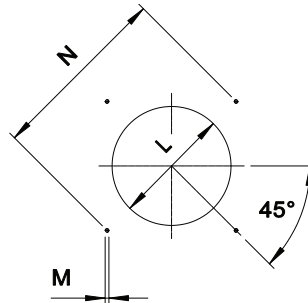

Fig. 4 Boiler plate

MODEL		L min	L *	L max	M	N min	N *	N max
K 190/M	mm	280	280	320	M14	396	424	438
K 250/M	mm	280	280	320	M14	396	424	438

\* The dimensions of the boiler plate (threaded holes or studs) must be as indicated in the drawing.

## FLAME TUBE LENGTH

Flame tube length must be selected based on the specifications supplied by boiler manufacturer and, in any case, it must be greater than the thickness of the boiler door included its insulation.

In case of boilers with flame inversion or front flue combustion chambers, it is necessary to insulate the area between the flame tube and front door with refractory material. This protection material must not impede flame tube extraction.

MODEL		TL *
K 190/M	mm	481
K 250/M	mm	481

\* For different flame lengths, please contact our Technical-Sales Department.

**PRODUCT SPECIFICATION****SHORT DESCRIPTION**

Dual fuel burners for gas and light-oil two stages progressive (hi-low flame) or modulating (PID fully modulating) if equipped with addition of optional modulation kit and probe.

**DETAILED SPECIFICATION**

Gas and Light-oil burner two stages progressive (hi-low flame) or modulating (PID fully modulating) if equipped with addition of optional modulation kit and probe; composed by:

- Fan at high pressurisation;
- Combustion head with adjustment at high performance and elevated flame stability equipped with steel blast tube and steel flame disc;
- Flange and insulating gasket for fixing at boiler;
- Three-phase power supply;
- Safety air pressure switch to stop the burner in lock-out in case of failed or anomalous fan operation;
- Gas train with safety valve class A, adjustment valve class A and valve proving system;
- UV probe for the flame detection;
- IP 40 electric protection level;
- Spherical gas valve servo-controlled; progressive start and free way passage with total opening;
- Light-oil pressure regulator servo-controlled;
- Servomotor for air shutter, for the spherical gas valve and for the light-oil pressure regulator;
- Moving shutter with total closure when idle in order to reduce at the least energy losses related to boiler cooling down;
- Easy extraction of combustion head without get off the burners by boiler;
- Maximum gas pressure switch to stop the burner in lock-out in case of the gas pressure is higher then the set point value;
- Maximum light-oil pressure switch to stop the burner in case of the light-oil pressure on the return is higher then the set point value;
- Dedicated motor for the activation of the light-oil pump;
- Manual switch for the fuel selection "OIL - GAS";
- Pilot ignition (only for GAS fuel);
- Set up for the additional specific kit that transforms burner operation as modulating i.e. the modulating kit allows to supply any power between the minimum and the maximum value based on instantaneous loading request.

**CONFORMING TO:**

- CE rules;
- 2014/30/UE Directive E.M.C.;
- 2014/35/UE Directive L.V.;
- 2014/68/EU Directive M.D.;
- 97/23/CE Directive P.E.D.;
- 2009/142/CE Directive GAS;
- Reference rules: EN676 (gas) - EN267 (liquid fuel) - EN746-2 (industrial thermoprocessing equipment).

**STANDARD EQUIPMENT**

- Flexible hoses for connection;
- Line filter;
- Isomart gasket;
- Nozzle;
- Flange with insulating gasket;
- Burner nameplate;
- Warranty;
- Instruction handbook for installation, use and maintenance.

**OPTIONAL**

- Power modulating kits for temperatures;
- Power modulating kits for pressures;
- Temperature probe 0°C-400°C (PT 100 a 0° C);
- Temperature probe 0°C-1200°C (K probe);
- Pressure probe 0-3 bar, 0-6 bar, 0-16 bar, 0-20 bar, 0-30 bar;
- Noise protection;
- Antivibration couplings;
- Handle gas taps.

The illustrations and data here shown are indicative. F.B.R. Bruciatori S.r.l. reserves the right to bring, without any obligation of warning, any changes that would be appropriate to the continuing development of their products.