

GAS X3/2 CE-LX - GAS X4/2 CE-LX

Gas burners two stages composed by: die-cast aluminum body, fan at high pressurisation, combustion head with adjustment at high efficiency and high flame stability and protection cover with noise reduction plate.

Compact overall dimensions and disposition rationalized of the components with accessibility facilitated for the operations of setting and maintenance.

Gas train complete of one-block valve A class (1st stage slow opening + safety), minimum gas pressure switch and filter stabilizer.

Complete of connector plug / socket 7 poles, connector plug / socket 5 poles (for the 2nd stage modulation), flange and gasket for installation on generator.



Fig. 1 GAS X3/2 CE-LX



Fig. 2 GAS X4/2 CE-LX

TECHNICAL DATA AND OPERATING RANGE DIAGRAM

MODEL		GAS X3/2 CE-LX	GAS X4/2 CE-LX
Thermal power min. 1°st. / min. 2°st. - max. 2°st. *	[Mcal/h]	34.7/60-150	45/90-211
Thermal power min. 1°st. / min. 2°st. - max. 2°st. *	[kW]	40.3/69.8-174	52/104-245
Gas flow G20 (NATURAL GAS) min. 1°st. / min. 2°st. - max. 2°st. *	[Nm³/h]	4/7-17.5	5.2/10.5-24.6
Fuel: NATURAL GAS (second family)			
Fuel category: I2R,I2H,I2L,I2E,I2E+,I2Er,I2ELL,I2E(R)B			
NOx **	[mg/kWh]	<80: class 3 (EN 676)	
Intermittent working operation (min. 1 stop every 24 hours) two stages			
Environmental conditions operation / storage:	-15...+40°C / -20...+70°C, rel. humidity max. 80%		
Max. temperature combustion air	[°C]	60	
Min. pressure gas train D1"-S NATURAL GAS ***	[mbar]	15.5	26
Min. pressure gas train D1"1/4-S NATURAL GAS ***	[mbar]	13.5	19.5
Min. pressure gas train D1"1/2-S NATURAL GAS ***	[mbar]	13	16.5
Max. pressure at the entry of valves (Pe. max)	[mbar]	360	
Nominal electric power	[W]	260	260
Fan motor	[W]	200	200
Nominal motor current absorption	[A]	1.1	1.1
Power supply:	1/N~230V-50Hz		
Electric protection degree:	IP 40		
Noisiness **** min. - max.	[dB(A)]	66-68	66-68
Burner weight	[kg]	15	17

* Reference conditions: Environment temperature 20°C - Barometric pressure 1013 mbars - Altitude 0 metre (sea level).

** To obtain this low Nox emission like in the declaration, it's necessary to couple the burner to the proper boiler for this application: boilers with 3 turns for the exhaust gas, condensing boilers and any generator with direct exhaust outlet and the thermal load isn't higher then 1,1 MW/m³.

*** Minimal feeding-gas pressure to the gas train to get the maximum power of the burner, considering counter-pressure in combustion chamber of value 0 (zero).

**** Measured sonorous pressure in the laboratory combustion, with functional burner on beta boiler to 1 metre of distance (UNI EN ISO 3746 law).

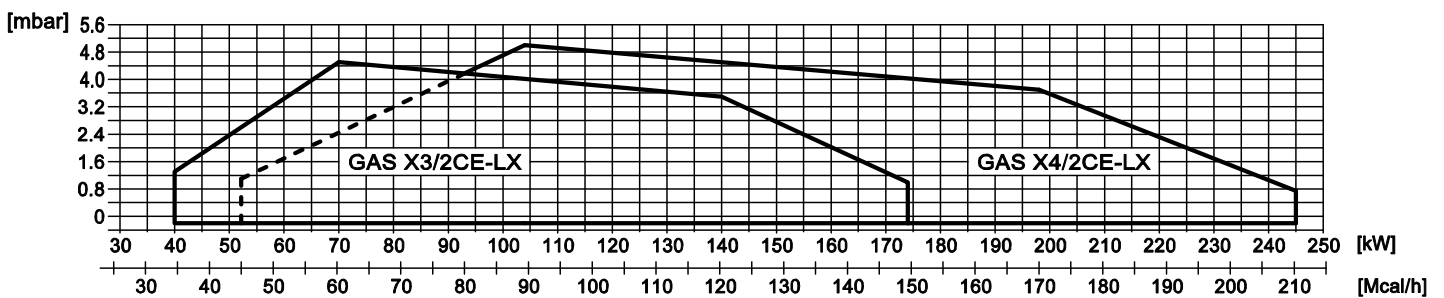

Fig. 3 X = Thermal power Y = Pression in the combustion chamber

The firing rates has been obtained based on test boilers in accordance with EN267 standards and are indicative of matching the burner to the boiler. For the correct operation of the burner, combustion chamber dimensions must be in accordance with current regulation. In case of non-compliance, contact the manufacturer.



FBR

DIMENSIONS [MM]

GAS BURNERS 2 STAGES LOW NOX



SK071071_A_en

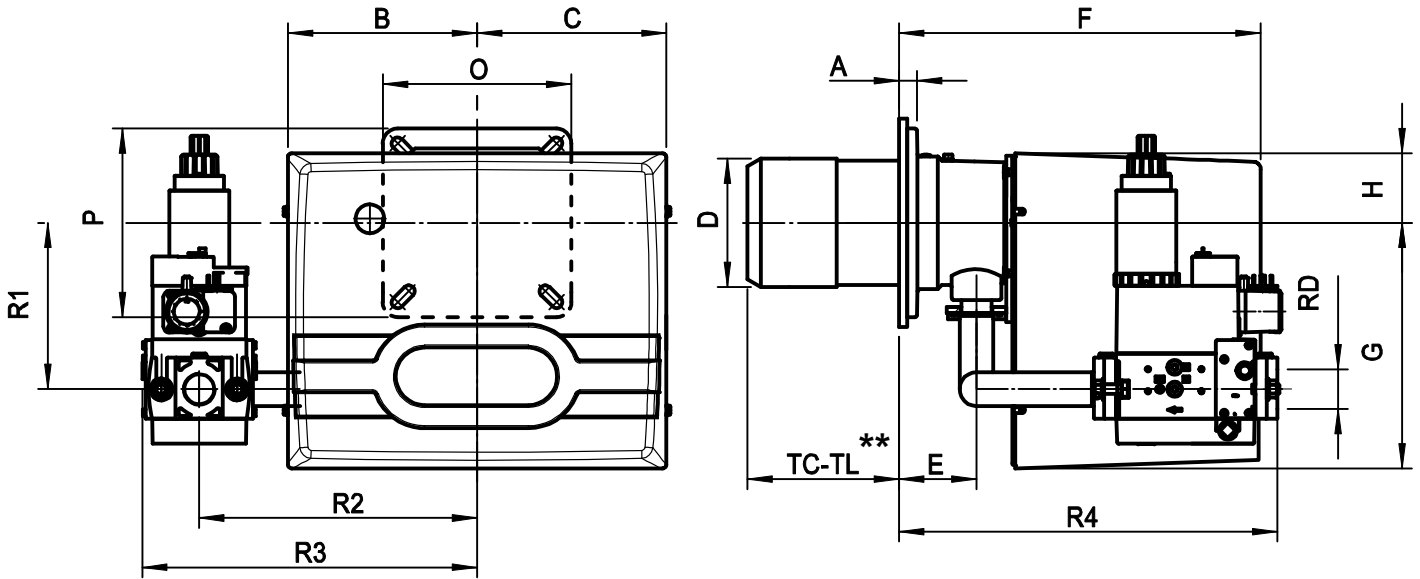
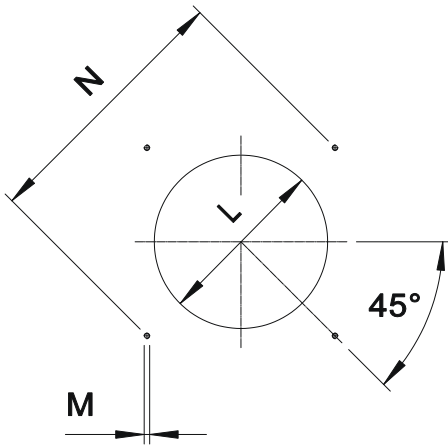

Fig. 4 Dimensions GAS X3/2 CE-LX - GAS X4/2 CE-LX

MODEL	A	B	C	D	E	F	G	H	O	P	R1	R2	R3	R4	RD	Gas train weight
GAS X3/2 CE-LX - D1"-S	20	185	195	107	54	340	248	70	200	160	152	280	337	300	1"	6 kg
GAS X3/2 CE-LX - D1"1/4-S	20	185	195	107	54	340	248	70	200	160	152	280	337	300	1"1/4	6 kg
GAS X3/2 CE-LX - D1"1/2-S	20	185	195	107	54	340	248	70	200	160	152	280	330	443	1"1/2	9 kg
GAS X4/2 CE-LX - D1"-S	20	185	195	129	78	368	248	70	200	200	158	280	337	320	1"	6 kg
GAS X4/2 CE-LX - D1"1/4-S	20	185	195	129	78	368	248	70	200	200	158	280	337	320	1"1/4	6 kg
GAS X4/2 CE-LX - D1"1/2-S	20	185	195	129	78	368	248	70	200	200	158	280	330	467	1"1/2	9 kg

** TC-TL: see "flame tube length"



* Suggested dimension of connection between burner and generator.

Fig. 5 Boiler plate

MODEL		L min	L *	L max	M	N min	N *	N max
GAS X3/2 CE-LX	mm	120	130	140	M8	150	170	170
GAS X4/2 CE-LX	mm	135	140	160	M10	170	205	226

FLAME TUBE LENGTH

Flame tube length must be selected based on the specifications supplied by boiler manufacturer and, in any case, it must be greater than the thickness of the boiler door included its insulation.

In case of boilers with flame inversion or front flue combustion chambers, it is necessary to insulate the area between the flame tube and front door with refractory material. This protection material must not impede flame tube extraction.

MODEL		TC	TL **
GAS X3/2 CE-LX	mm	130	250
GAS X4/2 CE-LX	mm	160	280

** For different flame lengths, please contact our Technical-Sales Department.

PRODUCT SPECIFICATION**SHORT DESCRIPTION**

Burners for gas two stages low emissions certified in conformity with CE 676 class 3 (NO_x < 80 mg/kWh).

DETAILED SPECIFICATION

Burner for gas two stages low emissions certified in conformity with CE 676 class 3 (NO_x < 80 mg/kWh); composed by:

- Aluminum body;
- Fan at high pressurisation;
- Combustion head with adjustment at high performance and elevated flame stability equipped with steel blast tube and steel flame disc;
- Protection cover with noise reduction plate;
- Flange and insulating gasket for fixing at boiler;
- Single phase power supply;
- Safety air pressure switch to stop the burner in lock-out in case of failed or anomalous fan operation;
- Gas train completely assembled and tested; complete of one-block valve A class (1st stage + 2nd stage slow opening + safety), minimum gas pressure switch and filter stabilizer;
- Ionisation probe for flame detection;
- IP 40 electric protection level;
- Servomotor for air shutter and for the consent of the 2nd stage gas valve;
- Moving shutter with total closure when idle in order to reduce at the least energy losses related to boiler cooling down.

CONFORMING TO:

- CE rules;
- 2014/30/UE Directive E.M.C.;
- 2014/35/UE Directive L.V.;
- 2014/68/EU Directive M.D.;
- 97/23/CE Directive P.E.D.;
- 2009/142/CE Directive GAS;
- Reference rules: EN676 (gas) - EN746-2 (industrial thermoprocessing equipment).

STANDARD EQUIPMENT

- Isomart gasket;
- Flange with insulating gasket;
- Burner nameplate;
- Warranty;
- Instruction handbook for installation, use and maintenance.

OPTIONAL

- Antivibration couplings;
- Handle gas taps.