

GAS P190/MCE - GAS P250/MCE - GAS P300/MCE

Burners for gas two stages progressive (hi-low flame) or modulating (PID fully modulating) if equipped with addition of optional modulation kit and probe.

They are composed by: fan at high pressurisation and combustion head with adjustment at high efficiency and high flame stability.

Compact overall dimensions and disposition rationalized of the components with accessibility facilitated for the operations of setting and maintenance.

Available in the versions METHANE (natural gas) or L.P.G. (to specify at the order) on demand specific versions for town gas, coal gas or biogas.

Gas train completely assembled and tested; complete of working valve with flow adjustment, safety valve, minimum gas pressure switch and gas filter.

Complete of flange and gasket for installation on generator.

Available also special versions with INVERTER and ELECTRONIC BURNER CONTROL.

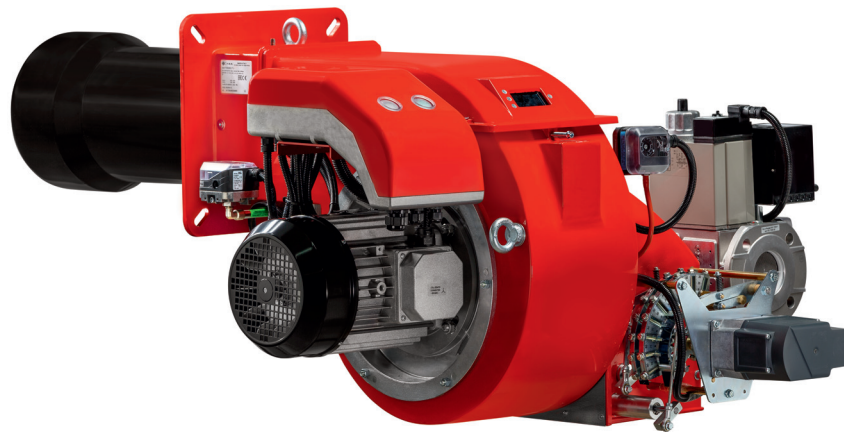

Fig. 1 GAS P250/MCE



Fig. 2 GAS P250/MCE

TECHNICAL DATA GAS P190/MCE - GAS P250/MCE - GAS P300/MCE

MODEL		GAS P190/MCE	GAS P250/MCE	GAS P300/MCE
Thermal power min. 1°st. / min. 2°st. - max. 2°st. *	[Mcal/h]	300/900-1900	330/1000-2500	400/1200-3000
Thermal power min. 1°st. / min. 2°st. - max. 2°st. *	[kW]	349/1046-2209	384/1163-2907	465/1395-3488
Gas flow G20 (NATURAL GAS) min. 1°st. / min. 2°st. - max. 2°st. *	[Nm³/h]	35/105-222	39/117-292	47/140-351
Gas flow G31 (L.P.G.) min. 1°st. / min. 2°st. - max. 2°st. *	[Nm³/h]	14/41-86	15/45-113	18/54-135
Fuel: NATURAL GAS (second family) - L.P.G. (third family)				
Fuel category:		I2R,I2H,I2L,I2E,I2E+,I2Er,I2ELL,I2E(R)B/I3B/P,I3+,I3P,I3B,I3R		
Intermittent working operation (min. 1 stop every 24 hours) two stages progressive or modulating				
Environmental conditions operation / storage:		-15...+40°C / -20...+70°C, rel. humidity max. 80%		
Max. temperature combustion air	[°C]	60	60	60
Minimum pressure gas train D2" - FS50 NATURAL GAS/L.P.G. **	[mbar]	107/43	181/94	268/120
Minimum pressure gas train DN65-FS65 NATURAL GAS/L.P.G. **	[mbar]	46/31	84/54	112/62
Minimum pressure gas train DN80-FS80 NATURAL GAS/L.P.G. **	[mbar]	30/25	56/45	72/48
Minimum pressure gas train DN100-FS100 NATURAL GAS/L.P.G. **	[mbar]	21/22	39/38	52/40
Maximum pressure at the entry of valves (Pe. max) ****	[mbar]	360-500	360-500	360-500
Nominal electric power	[kW]	5.8	7.8	7.8
Fan motor	[kW]	5.5	7.5	7.5
Nominal motor current absorption	[A]	12.3	16.3	16.3
Nominal auxiliary absorption	[A]	0.6	0.6	0.6
Power supply:		3~400V,1N~230V - 50Hz		
Electric protection degree:		IP40	IP40	IP40
Noisiness *** min. - max.	[dB(A)]	79-82	81-85	81-85
Burner weight	[kg]	107	108	113

* Reference conditions: Environment temperature 20°C - Barometric pressure 1013 mbars - Altitude 0 metre (sea level).

** Minimal feeding-gas pressure to the gas train to get the maximum power of the burner, considering counter-pressure in combustion chamber of value 0 (zero).

*** Measured sonorous pressure in the laboratory combustion, with functional burner on beta boiler to 1 metre of distance (UNI EN ISO 3746 law - method of control Class 3 - The tolerance of the measured pressure can be taken equal to ± 1 [dB(A)]).

**** 360 mbar for "Honeywell" mod.; 500 mbar for "Dungs" and "Siemens" mod.; 200 mbar for "Krom".

OPERATING RANGE DIAGRAM GAS P190/MCE - GAS P250/MCE - GAS P300/MCE

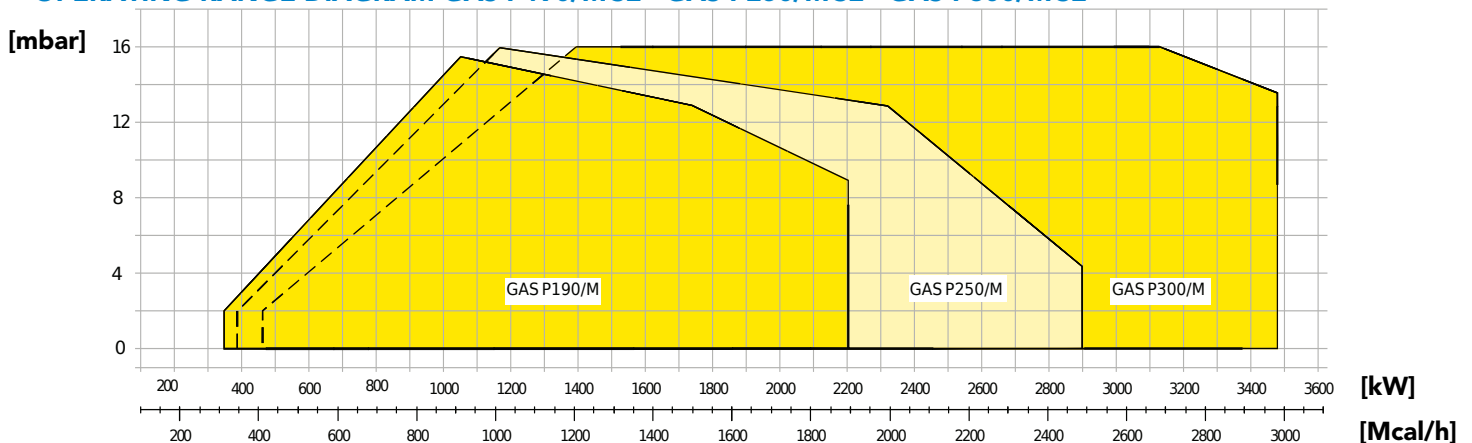

Fig. 3 X = Thermal power Y = Pression in the combustion chamber

The firing rates has been obtained based on test boilers in accordance with EN267 standards and are indicative of matching the burner to the boiler. For the correct operation of the burner, combustion chamber dimensions must be in accordance with current regulation. In case of non-compliance, contact the manufacturer.

DIMENSIONS [MM]

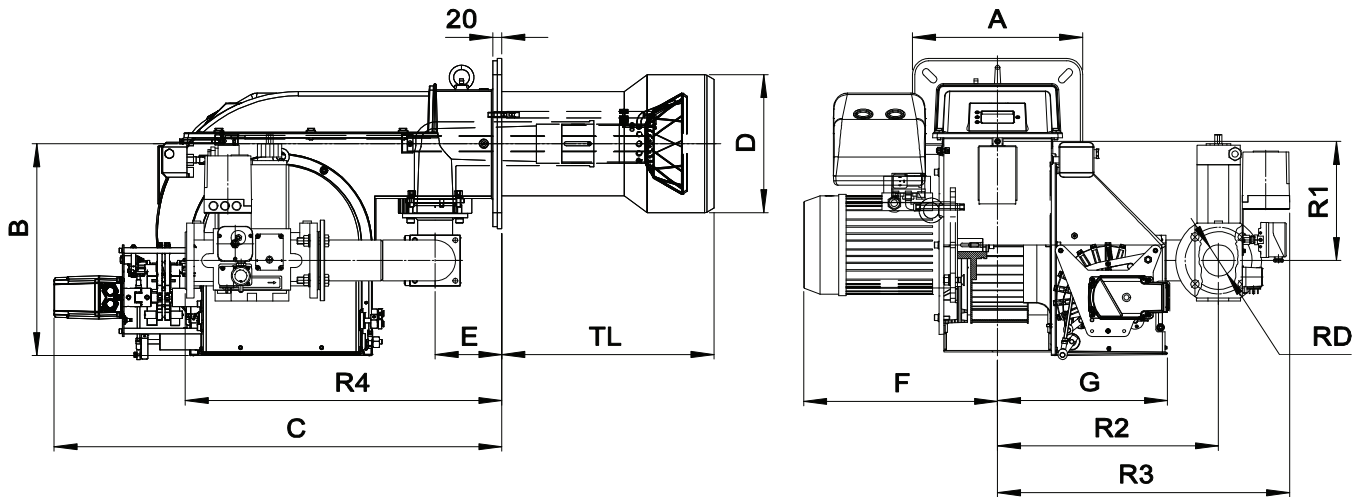
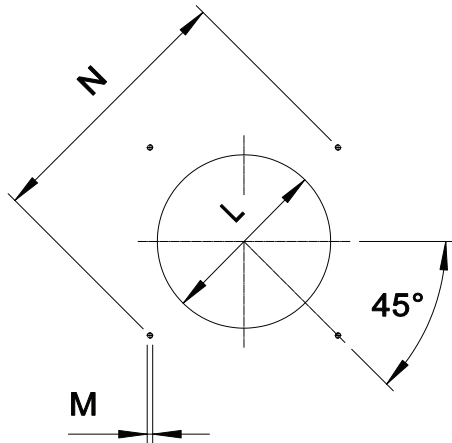

Fig. 4 Dimensions GAS P190/MCE - GAS P250/MCE - GAS P300/MCE

MODEL	A	B	C	D	E	F	G	R1	R2	R3	R4	RD	Gas train weight
GAS P190/MCE - D2" FS50	360	453	974	265	145	422	363	254	509	672	504	Rp 2	21 kg
GAS P190/MCE - DN65 FS65	360	453	974	265	145	422	363	254	480	634	688	DN65	40 kg
GAS P190/MCE - DN80 FS80	360	453	974	265	145	422	363	254	480	647	708	DN80	46 kg
GAS P190/MCE - DN100 FS100	360	453	974	265	145	422	363	254	480	654	748	DN100	52 kg
GAS P250/MCE - D2" FS50	360	453	974	270	145	422	363	254	509	672	504	Rp 2	21 kg
GAS P250/MCE - DN65 FS65	360	453	974	270	145	422	363	254	480	634	688	DN65	40 kg
GAS P250/MCE - DN80 FS80	360	453	974	270	145	422	363	254	480	647	708	DN80	46 kg
GAS P250/MCE - DN100 FS100	360	453	974	270	145	422	363	254	480	654	748	DN100	52 kg
GAS P300/MCE - D2" FS50	360	453	974	300	145	422	363	254	509	672	504	Rp 2	21 kg
GAS P300/MCE - DN65 FS65	360	453	974	300	145	422	363	254	480	634	688	DN65	40 kg
GAS P300/MCE - DN80 FS80	360	453	974	300	145	422	363	254	480	647	708	DN80	46 kg
GAS P300/MCE - DN100 FS100	360	453	974	300	145	422	363	254	480	654	748	DN100	52 kg



* Suggested dimension of connection between burner and generator.

Fig. 5 Boiler plate

MODEL		L min	L *	L max	M	N min	N *	N max
GAS P190/MCE	mm	280	280	320	M14	396	424	438
GAS P250/MCE	mm	280	280	320	M14	396	424	438
GAS P300/MCE	mm	310	310	320	M14	396	424	438

FLAME TUBE LENGTH

Flame tube length must be selected based on the specifications supplied by boiler manufacturer and, in any case, it must be greater than the thickness of the boiler door included its insulation.

In case of boilers with flame inversion or front flue combustion chambers, it is necessary to insulate the area between the flame tube and front door with refractory material. This protection material must not impede flame tube extraction.

MODEL		TL **
GAS P190/MCE	mm	495
GAS P250/MCE	mm	495
GAS P300/MCE	mm	460

** For different flame lengths, please contact our Technical-Sales Department.

BURNER SIGNAL DESCRIPTION

In the picture below there are indicated all the signalation present on the burner:

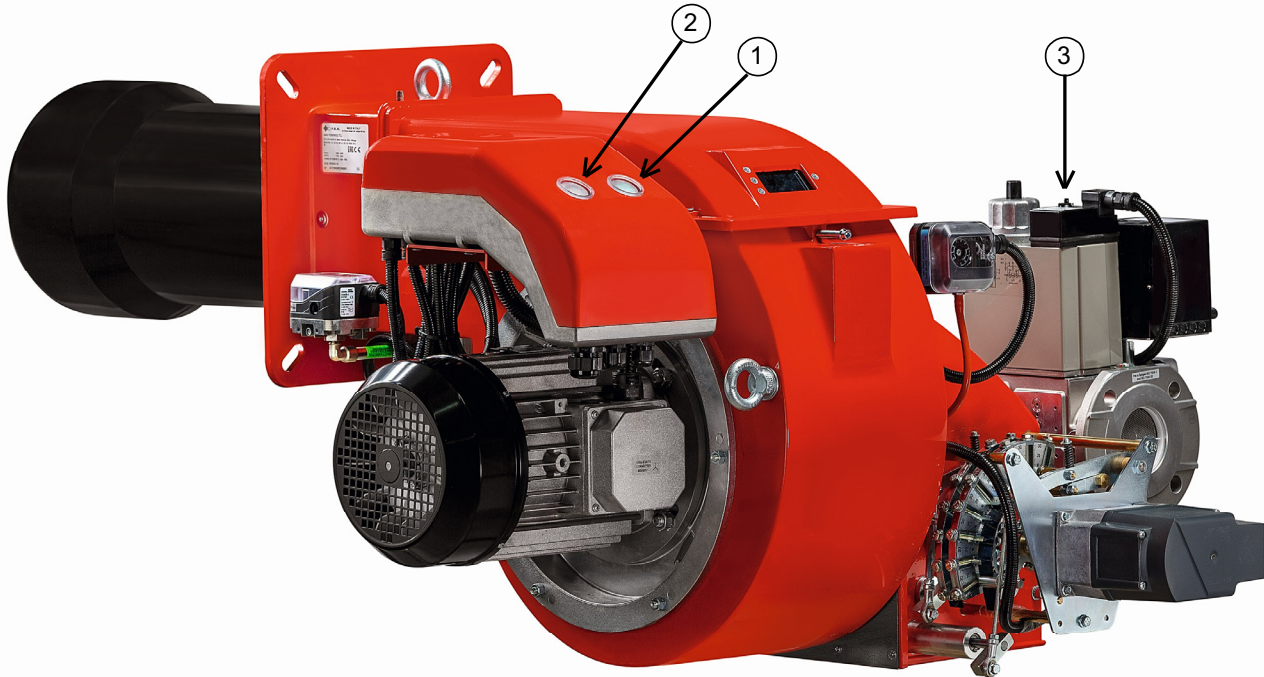



Fig. 6 Burner signal description

LEGEND

- 1) ON/OFF button
- 2) Reset from lockout button + status lamp
- 3) GAS valve lamp *

* In the gas train DN65-FS65, DN80-FS80 and DN100-FS100 there are 2 lamps.

 The multicolor signal lamp in the lockout reset button (pos.2) is the key indicating element for visual diagnostics and interface diagnostics.

In normal operation, the different operating states are indicated in the form of color codes; please refer to electrical device handbook supplied with the present instructions.

 After a non-alterable lockout, the red signal lamp in the lockout reset button (pos.2) lights up. By pressing the lockout reset button (pos.2) for more than 3 seconds, the visual diagnostics of the cause of fault can be activated; please refer to electrical device handbook supplied with the present instructions.

For close the diagnostics mode and for switch on the burner again, it is necessary to reset the burner control. Press the lockout reset button (pos.2) for about 1 second (<3 seconds).

 After a non-alterable lockout, the red signal lamp in the lockout reset button (pos.2) lights up. For reset the control box press the lockout reset button (pos.2) for about 1 second (<3 seconds).

PRODUCT SPECIFICATION**SHORT DESCRIPTION**

Burners for gas two stages progressive (hi-low flame) or modulating (PID fully modulating) if equipped with addition of optional modulation kit and probe.

DETAILED SPECIFICATION

Burner for gas two stages progressive (hi-low flame) or modulating (PID fully modulating) if equipped with addition of optional modulation kit and probe; composed by:

- Fan at high pressurisation;
- Combustion head with adjustment at high performance and elevated flame stability equipped with inox steel blast tube and steel flame disc;
- Flange and insulating gasket for fixing at boiler;
- Three-phase power supply;
- Safety air pressure switch to stop the burner in lock-out in case of failed or anomalous fan operation;
- Gas train with safety valve class A, adjustment valve class A and valve proving system;
- Ionisation probe for flame detection;
- IP 40 electric protection level;
- Spherical gas valve servo-controlled; progressive start and free way passage with total opening;
- Servomotor for air shutter and for the spherical gas valve;
- Moving shutter with total closure when idle in order to reduce at the least energy losses related to boiler cooling down;
- Easy extraction of combustion head without get off the burners by boiler;
- Maximum gas pressure switch to stop the burner in lock-out in case of the gas pressure is higher then the set point value;
- Set up for the additional specific kit that transforms burner operation as modulating i.e. the modulating kit allows to supply any power between the minimum and the maximum value based on instantaneous loading request.

CONFORMING TO:

- CE rules;
- 2014/30/UE Directive E.M.C.;
- 2014/35/UE Directive L.V.;
- 2014/68/EU Directive M.D.;
- 97/23/CE Directive P.E.D.;
- 2009/142/CE Directive GAS;
- Reference rules: EN676 (gas) - EN746-2 (industrial thermoprocessing equipment).

STANDARD EQUIPMENT

- Isomart gasket;
- Flange with insulating gasket;
- Burner nameplate;
- Warranty;
- Instruction handbook for installation, use and maintenance.

OPTIONAL

- Power modulating kits for temperatures;
- Power modulating kits for pressures;
- Temperature probe 0°C-400°C (PT 100 a 0° C);
- Temperature probe 0°C-1200°C (K probe);
- Pressure probe 0-3 bar, 0-6 bar, 0-16 bar, 0-20 bar, 0-30 bar;
- Noise protection;
- Antivibration couplings;
- Handle gas taps.