



Burners for gas, single stage, aluminium frame, protection cover in steel and specific features for the application on industrial ovens and bakery ovens, combustion head with adjustment at high efficiency and high flame stability.

Available in the versions Methane (natural gas) or G.P.L. (to specify at the order) on demand specific versions for town gas, coal gas or biogas.

Compact overall dimensions and disposition rationalized of the components with accessibility facilitated for the operations of setting and maintenance.

Gas train complete of working valve with flow adjustment, safety valve, gas pressure switch, filter stabiliser of gas pressure, completely assembled, electrically linked and tested.

Complete of connector 7 poles, flange and gasket for installation on ovens.

TECHNICAL DATA

MODEL		GAS X1 F	GAS X2 F	GAS X3 F	GAS X4 F	GAS X5 F
Thermal power min-max*	Mcal/h	20-50	35-80	60-150	100-200	130-300
	kW	23-58	40.5-93	70-174	116-232	151-349
Flow-rate G20 (NATURAL GAS) min-max*	Nm ³ /h	2.3-5.8	4.1-9.4	7-17.4	11.6-23.2	15.2-35
Flow-rate G31 (LPG) min-max*	Nm ³ /h	0.9-2.3	1.6-3.6	2.7-6.5	4.5-9	5.8-13.5
Fuel	NATURAL GAS (second family) - LPG (third family)					
Combustible category	2R 2H 2L 2E+ 2E+ 2ELL 2E(R)B 38/P 3+ 3P 38 3R					
Intermittent operation (min. 1 stop every 24 hours) at 1 stage						
Allowed environment conditions on running/stock	-15...+40°C/-20...+70°C, rel. humidity max 80%					
Maximum inlet pressure to the valves	°C	60	60	60	60	60
Min. pressure gas train D1/2"-S NATURAL GAS/LPG**	mbar	14/31	-	-	-	-
Min. pressure gas train D3/4"-S NATURAL GAS/LPG**	mbar	-	18/24	-	-	-
Min. pressure gas train D1"-S NATURAL GAS/LPG**	mbar	-	-	14-31	14/21	27/33
Min. pressure gas train D1"1/4-S NATURAL GAS/LPG**	mbar	-	-	-	-	16/25
Max pressure on the valve's inlet	mbar	60	360	360	360	360
Nominal electric power	W	110	130	200	226	540
Fan motor	W	75	75	110	200	370
Power absorbed	A	0.6	0.6	0.9	1.1	2.4
Power supply	1/N~230V-50Hz					
Degree of electric protection		IP40	IP40	IP40	IP40	IP40
Noisiness***min-max	dBA	59-60	60-61	64-66	64-66	67-71
Weight	kg	13	13	16	18	29

* Reference conditions: Room temperature 20°C - Atmospheric pressure 1013 mbars - Altitude 0m (sea level)

** Least pressure of feeding of the gas to the train to get the maximum power of the burner considering against pressure in chamber of value combustion 0 (zero)

*** Measured sonorous pressure in the laboratory combustion, with functional burner on beta boiler to 1 m of distance (UNI EN ISO 3746 law)

FIRING RATES: Thermal power - Pressure in combustion chamber

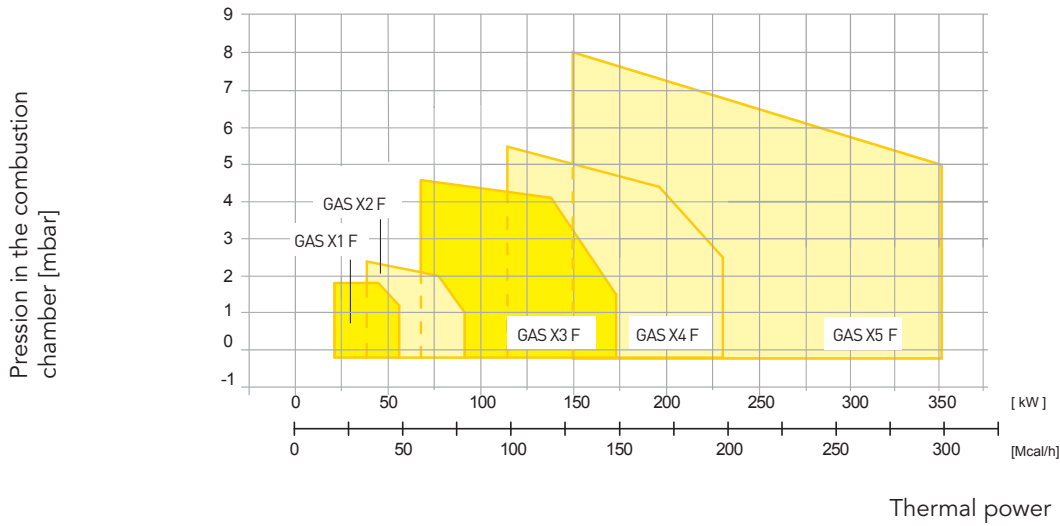

DIMENSIONS (mm)

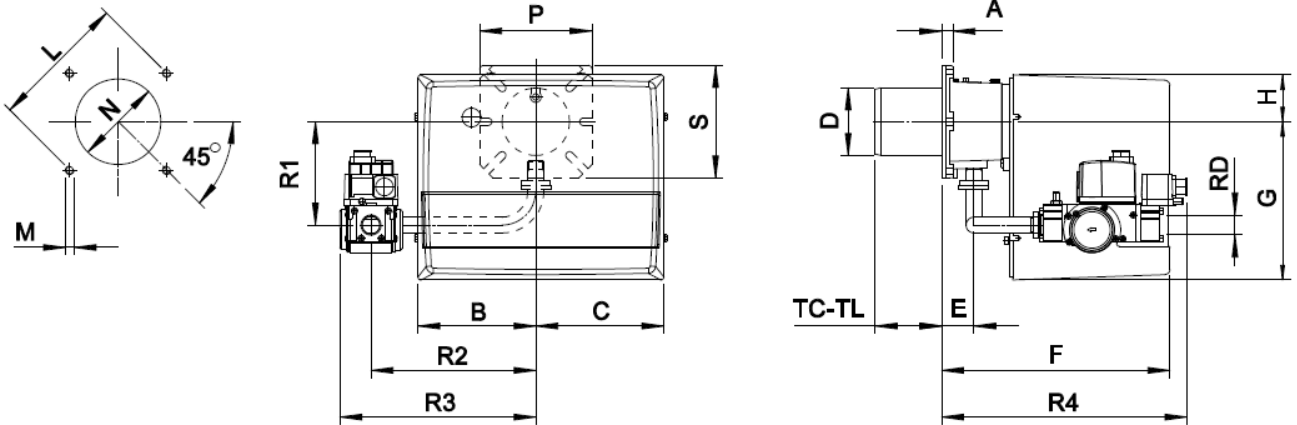

* Suggested dimension of connection between burner and generator

MODEL	A	B	C	D	E	F	G	H	L _{min}	L*	L _{max}	M	N _{min}	N*	N _{max}	P	S	TC	TL	R1	R2	R3	R4	RD
GAS X1 CE F - D1/2"-S	15	162	175	90	43	305	210	65	130	150	170	M8	100	110	130	150	150	90	150	132	200	254	240	1/2"
GAS X2 CE F - D3/4"-S	15	162	175	90	43	305	210	65	130	150	170	M8	100	110	130	150	150	90	150	138	220	262	328	3/4"
GAS X3 CE F - D1"-S	16	185	195	108	54	340	248	70	150	170	170	M8	120	130	140	190	150	130	250	168	280	337	361	1"
GAS X4 CE F - D1"-S	20	185	195	125	78	368	248	70	170	205	226	M10	130	140	160	200	200	160	280	173	280	337	385	1"
GAS X5 CE F - D1"-S	18	207	213	138	98	462	310	90	205	205	226	M10	150	150	180	200	200	250	335	160	305	362	403	1"
GAS X5 CE F - CT-D1"-S	18	207	213	138	98	462	310	90	205	205	226	M10	150	150	180	200	200	250	335	160	305	480	403	1"
GAS X5 CE F - D1"1/4-S	18	207	213	138	98	462	310	90	205	205	226	M10	150	150	180	200	200	250	335	160	305	362	450	1"1/4
GAS X5 CE F - CTD1"1/4-S	18	207	213	138	98	462	310	90	205	205	226	M10	150	150	180	200	200	250	335	160	305	480	450	1"1/4