

## KN 750-1000-1300-1500-1800/M MEC

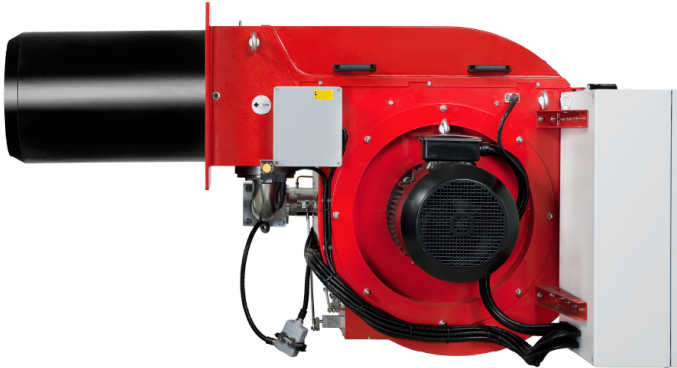

Fig. 1 KN 750-1000-1300-1500-1800/M MEC

Dual fuel burners for gas and heavy oil at 2 stages progressive (hi-low flame) or PID fully modulating if equipped with modulation kit and probe.

Fan at high pressurization, high efficiency combustion head with adjustment and high flame stability, pump skid, preheating tank and degaser,

Rational disposal of components with easy accessibility for calibration and maintenance operations.

Available versions for natural gas or L.P.G. (to be specified at the order).

Monoblock gas train includes working valve, safety valve and pressure stabilizer, minimum gas pressure switch and gas filter and is supplied already assembled, connected and tested.

The adoption of strong metal components makes the burner durable also in heavy duty conditions.

Burners are supplied with nozzle, fuel switch, gasket for installation on boiler, flexible hoses, line filter.

Also available in electronic cam version.



Fig. 2 Pump skid



TECHNICAL DATA KN 750/M MEC - KN 1000/M MEC - KN 1300/M MEC

MODEL		KN 750/M MEC	KN 1000/M MEC	KN 1300/M MEC
Thermal power min.1°st./min.2°st. -max.2°st. *	[Mcal/h]	1200/3400-7500	1200/3400-10000	1700/3600-11500
Thermal power min.1°st./min.2°st. -max.2°st. *	[kW]	1395/3953-8721	1395/3953-11628	1977/4186-13372
Gas flow G20 (NATURAL GAS) min.1°st./min.2°st. -max.2°st. *	[Nm³/h]	140/398-877	140/398-1170	199/421-1345
Gas flow G31 (L.P.G.) min.1°st./min.2°st. -max.2°st. *	[Nm³/h]	54/153-338	54/153-450	77/162-518
Fuel: NATURAL GAS (second family) - L.P.G. (third family)				
Fuel category:		I2R,I2H,I2L,I2E,I2E+,I2Er,I2ELL,I2E(R)B/I3B/P,I3+,I3P,I3B,I3R		
Intermittent working operation (min. 1 stop every 24 hours) two stages progressive or modulating				
Enviromental conditions operation / storage:		-15...+40°C / -20...+70°C , rel. humidity max. 80%		
Max temperature combustion air	[°C]	60	60	60
Min. pressure gas train DN65-S F65 NATURAL GAS/L.P.G. **	[mbar]	280/107	-/-	-/-
Min. pressure gas train DN80-S F80 NATURAL GAS/L.P.G. **	[mbar]	164/63	292/112	366/141
Min. pressure gas train DN100-S F100 NATURAL GAS/L.P.G. **	[mbar]	110/40	184/71	248/95
Min. pressure gas train DN125-S F125 NATURAL GAS/L.P.G. **	[mbar]	81/31	145/56	180/70
Max. pressure at the entry of the valves (Pe. max)	[mbar]	500	500	500
HEAVY-OIL flow min.1°st./min.2°st. -max.2°st. *	[kg/h]	122/347-765	122/347-765	173/367-1173
Fuel: HEAVY-OIL 5°-20°E at 50°C				
Nominal electric power	[kW]	25.5	34.5	41.5
Fan motor	[kW]	22	30	37
Pump motor	[kW]	3	4	4
Power supply:		3~400V-1/N~230V-50Hz	3~400V-1/N~230V-50Hz	3~400V-1/N~230V-50Hz
Degree of electric protection:		IP44	IP44	IP44
Noiseness *** max.	[dB(A)]	89	91	93

\* Reference conditions: Environment temperature 20°C - Barometric pressure 1013 mbars - Altitude 0 metre (sea level).

\*\* Minimal feeding-gas pressure to the gas train to get the maximum power of the burner, considering counter-pressure in combustion chamber of value 0 (zero).

\*\*\* Measured sonorous pressure in the laboratory combustion, with functional burner on beta boiler to 1 metre of distance (UNI EN ISO 3746 law).

OPERATING RANGE DIAGRAM KN 750/M MEC - KN 1000/M MEC - KN 1300/M MEC

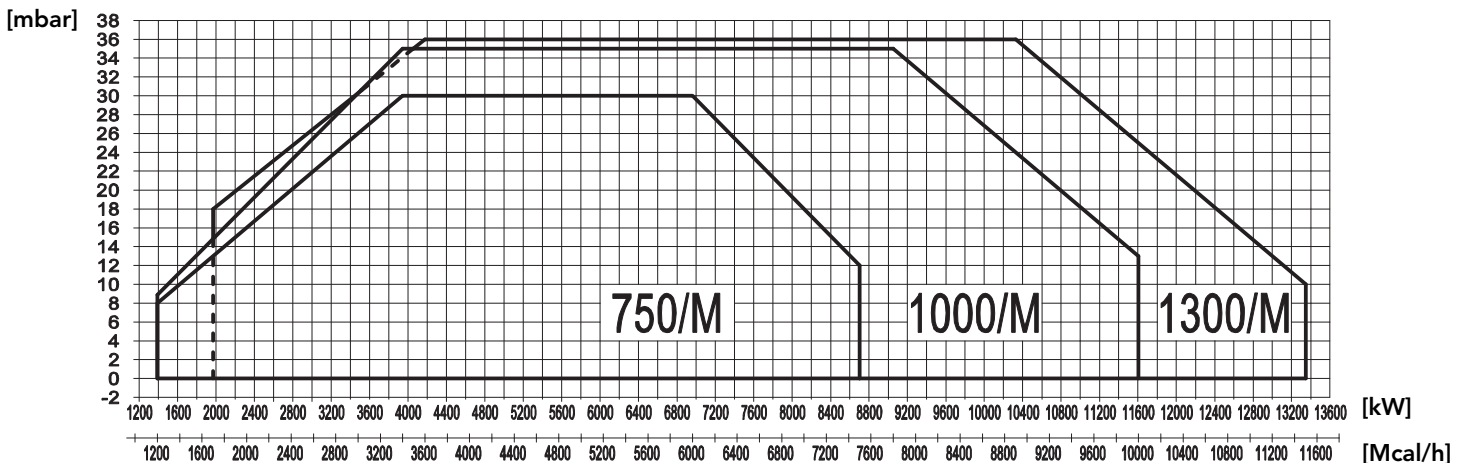

Fig. 3 X = Thermal power Y = Pression in the combustion chamber

The firing rates has been obtained based on test boilers in accordance with EN267 standards and are indicative of matching the burner to the boiler. For the correct operation of the burner, combustion chamber dimensions must be in accordance with current regulation. In case of non-compliance, contact the manufacturer.



TECHNICAL DATA KN 1500/M MEC - KN 1800/M MEC

MODEL		KN 1500/M MEC	KN 1800/M MEC
Thermal power min. 1°st. / min. 2°st. - max. 2°st. *	[Mcal/h]	1700/3600-13000	2000/5000-15000
Thermal power min. 1°st. / min. 2°st. - max. 2°st. *	[kW]	1977/4186-15116	2325/5815-17442
Gas flow G20 (NATURAL GAS) min. 1°st. / min. 2°st. - max. 2°st. *	[Nm³/h]	199/421-1520	234/585-1754
Gas flow G31 (L.P.G.) min. 1°st. / min. 2°st. - max. 2°st. *	[Nm³/h]	77/162-585	90/225-676
Fuel: NATURAL GAS (second family) - L.P.G. (third family)			
Fuel category:		I2R,I2H,I2L,I2E,I2E+,I2Er,I2ELL,I2E(R)B/I3B/P,I3+,I3P,I3B,I3R	
Intermittent working operation (min. 1 stop every 24 hours) two stages progressive or modulating			
Enviromental conditions operation / storage:		-15...+40°C / -20...+70°C , rel. humidity max. 80%	
Max temperature combustion air	[°C]	60	60
Minimum pressure gas train DN80-S F80 NATURAL GAS/L.P.G. **	[mbar]	-/142	-/-
Minimum pressure gas train DN100-S F100 NATURAL GAS/L.P.G. **	[mbar]	220/88	370/-
Minimum pressure gas train DN125-S F125 NATURAL GAS/L.P.G. **	[mbar]	191/70	307/-
Minimum pressure gas train DN150-S F150 NATURAL GAS/L.P.G. **	[mbar]	175/56	287/-
Maximum pressure at the entry of the valves (Pe. max)	[mbar]	500	500
HEAVY-OIL flow min. 1°st. / min. 2°st. - max. 2°st. *	[kg/h]	173/367-1326	204/510-1531
Fuel: HEAVY-OIL 5°-20°E at 50°C			
Nominal electric power	[kW]	49.5	61
Fan motor	[kW]	45	55
Pump motor	[kW]	4	5.5
Power supply:		3~400V-1/N~230V-50Hz	3~400V-1/N~230V-50Hz
Degree of electric protection:		IP44	IP44
Noiseness *** max.	[dB(A)]	97	101

\* Reference conditions: Environment temperature 20°C - Barometric pressure 1013 mbars - Altitude 0 metre (sea level).

\*\* Minimal feeding-gas pressure to the gas train to get the maximum power of the burner, considering counter-pressure in combustion chamber of value 0 (zero).

\*\*\* Measured sonorous pressure in the laboratory combustion, with functional burner on beta boiler to 1 metre of distance (UNI EN ISO 3746 law).

OPERATING RANGE DIAGRAM KN 1500/M MEC - KN 1800/M MEC

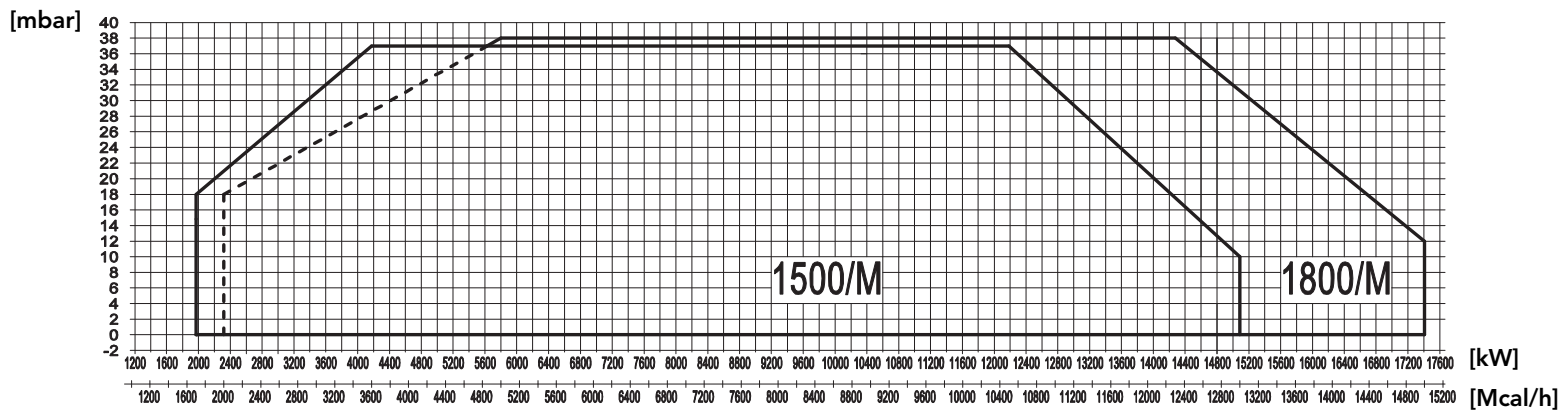

Fig. 4 X = Thermal power Y = Pression in the combustion chamber

The firing rates has been obtained based on test boilers in accordance with EN267 standards and are indicative of matching the burner to the boiler. For the correct operation of the burner, combustion chamber dimensions must be in accordance with current regulation. In case of non-compliance, contact the manufacturer.

## DIMENSIONS [mm]

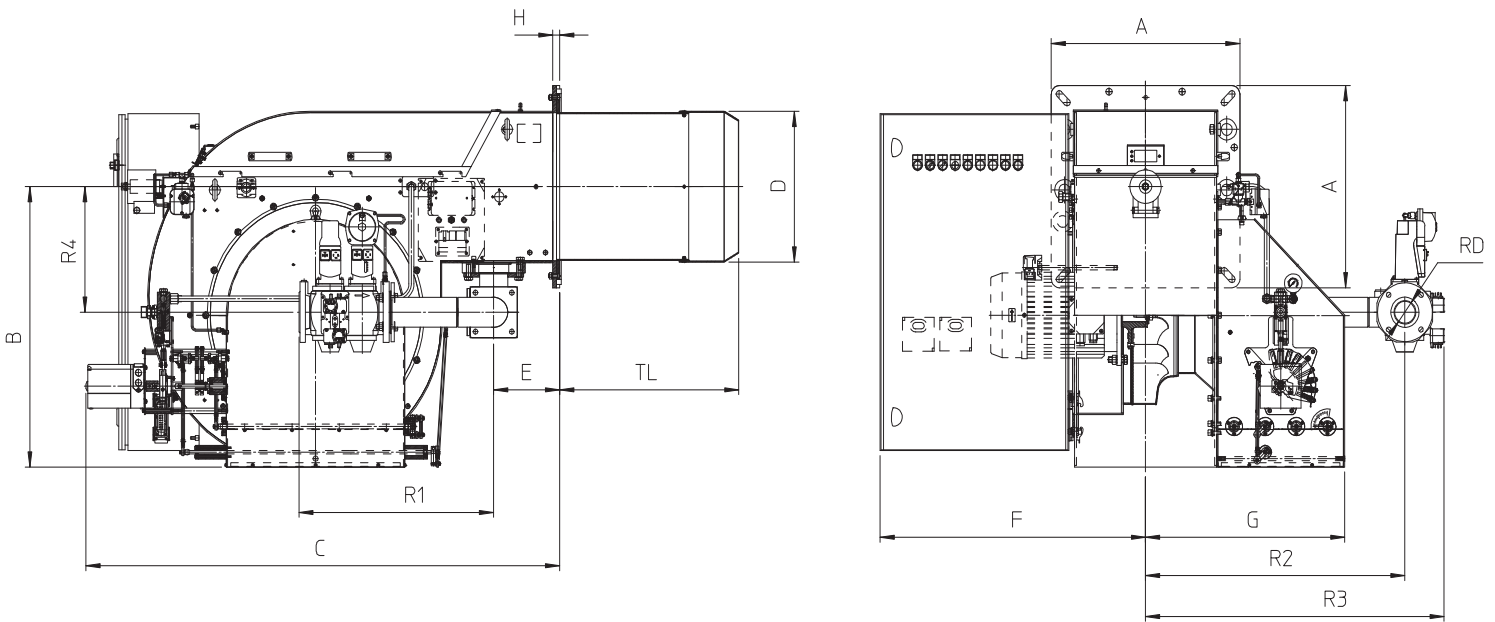
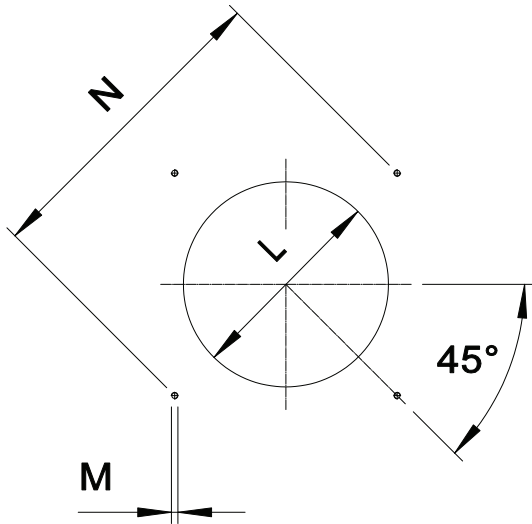

Fig. 5 Dimensions

MODEL	A	B	C	D	E	F	G	H	R1	R2	R3	R4	RD	TL
KN 750/M MEC DN65	600	832	1510	448	210	845	654	22	620	825	950	373	DN65	685
KN 750/M MEC DN80	600	832	1510	448	210	845	654	22	653	825	955	373	DN80	685
KN 750/M MEC DN100	600	832	1510	448	210	845	654	22	680	825	968	373	DN100	685
KN 750/M MEC DN125	600	832	1510	448	210	845	654	22	730	825	982	373	DN125	685
KN 1000/M MEC DN80	600	832	1510	468	210	845	654	22	653	825	955	373	DN80	685
KN 1000/M MEC DN100	600	832	1510	468	210	845	654	22	680	825	968	373	DN100	685
KN 1000/M MEC DN125	600	832	1510	468	210	845	654	22	730	825	982	373	DN125	685
KN 1300/M MEC DN80	600	832	1510	499	210	845	634	22	653	825	955	373	DN80	685
KN 1300/M MEC DN100	600	832	1510	499	210	845	634	22	680	825	968	373	DN100	685
KN 1300/M MEC DN125	600	832	1510	499	210	845	634	22	730	825	982	373	DN125	685
KN 1500/M MEC DN80	600	832	1510	499	210	845	634	22	653	825	955	373	DN80	685
KN 1500/M MEC DN100	600	832	1510	499	210	845	634	22	680	825	968	373	DN100	685
KN 1500/M MEC DN125	600	832	1510	499	210	845	634	22	730	825	982	373	DN125	685
KN 1500/M MEC DN150	600	832	1510	499	210	845	634	22	810	825	1001	373	DN150	685
KN 1800/M MEC DN100	700	884	1660	540	222	875	680	22	680	896	1021	476	DN100	685
KN 1800/M MEC DN125	700	884	1660	540	222	875	680	22	730	896	1035	476	DN125	685
KN 1800/M MEC DN150	700	884	1660	540	222	875	680	22	810	896	1054	476	DN150	685

**BOILER PLATE**



The dimensions of the boiler plate must be as indicated in the drawing.

**Fig. 6** Boiler plate

MODEL		M	N min	N *	N max	L min	L max
KN 750/M MEC	mm	M16	707	778	778	460	540
KN 1000/M MEC	mm	M16	707	778	778	480	540
KN 1300/M MEC	mm	M16	707	778	778	510	540
KN 1500/M MEC	mm	M16	707	778	778	510	540
KN 1800/M MEC	mm	M18	806	890	890	550	630

\* Suggested dimension

PUMP SKID DIMENSIONS [mm]

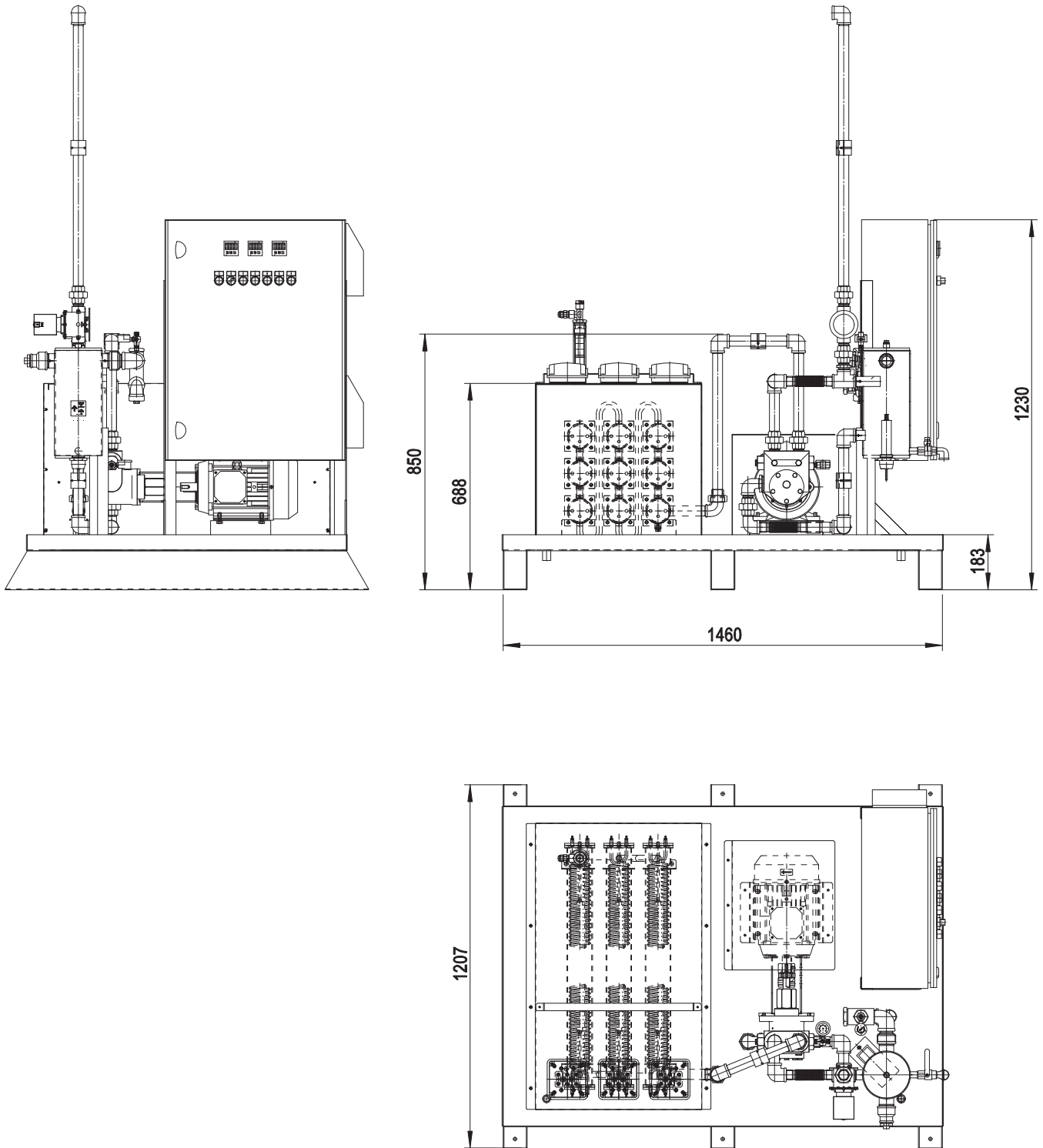

Fig. 7 Pump skid dimensions



## PRODUCT SPECIFICATION

### SHORT DESCRIPTION

Dual fuel burners for gas and heavy oil at 2 stages progressive (hi-low flame) or PID fully modulating if equipped with modulation kit and probe. Available versions for natural gas or L.P.G. (to be specified at the order) and both heavy oil as far as 20°E at 50°C and ecological heavy oil BTZ (low sulfur oil).

### DETAILED SPECIFICATION

Dual fuel burners with alternate supply natural gas or L.P.G. / heavy oil from 5 to 20°E at 50°C with possibility of modulating working (with optional modulation kit and probe), composed by:

- Burner frame made of steel completed by specific boiler plate;
- Centrifugal fan at high pressurization with reverse curved blades at low noisiness;
- Combustion head with adjustment at high performance and elevated flame stability equipped with inox steel blast tube and steel flame disc;
- Easy extraction of combustion head without get off the burners by bolier;
- Flange and insulating gasket for fixing at boiler;
- Minimum and maximum thermostat;
- Control box for control and supervision of burner;
- UV Photocell for flame detection;
- Gas/heavy oil selector;
- Three-phase power supply;
- IP44 electric protection level;
- Safety air pressure switch to stop the burner in case of failed or anomalous fan operation;
- Servomotor for air shutter, spherical gas valve and heavy oil pressure regulator;
- Mobile shutter with total closure when idle for minimize the energetic losses related at boiler cooling;
- Gas train with A class safety valve and A class adjustment valve;
- Leakage control with SIEMENS LDU11... valve proving system;
- Heavy oil gear pump operated by specific electric motor;
- Multistage pre-heating tank with specific flanged heaters at low density (anticracking and antigas);
- Pressure manometer on inlet pump;
- Thermometer inside pre-heating tank for temperature heavy-oil;
- Nozzle assembly with magnet to control inlet/return needle nozzle;
- Double filter between pump and nozzle;
- Set up for the additional specific kit that transforms burner operation as modulating i.e.the modulating kit allows to supply any power between the minimum and maximum value based on instantaneous loading request.

### CONFORMING TO:

- CE rules;
- 2004/108/CE Directive E.M.C.;
- 2006/95/CE Directive L.V.;
- 2006/42/CE Directive M.D.;
- 97/23/CE Directive P.E.D.;
- 2009/142/CE Directive GAS;
- Reference rules: EN676 (gas) - EN267 (liquid fuel) - EN746-2 (industrial thermoprocessing equipment).

### STANDARD EQUIPMENT:

- Flexible pipes for connection;
- line filter;
- isomart gasket;
- nozzle;
- flange with insulating gasket;
- burner nameplate;
- warranty;
- instruction handbook for installation, use and maintenance.



### OPTIONAL:

- Power modulating kits for temperatures;
- power modulating kits for pressures;
- temperature probe 0°-250°C (PT 100 ohm at 0°C);
- temperature probe 0°-1200°C (K probe);
- pressure probe 0-3 bar, 0-6 bar, 0-16 bar, 0-20 bar, 0-30 bar;
- noise protection.

The illustrations and data here shown are indicative. F.B.R. Bruciatori S.r.l. reserves the right to bring, without any obligation of warning, any changes that would be appropriate to the continuing development of their products.